

Earthing components and accessories

Earthing Accessories

Earth Rod Inspection Box

Part No.	Size (mm) width x length x height
GEB-UK	95 x 95 x 55
GEB	95 x 95 x 55

Material: Polyamide 6/6.
Complete with fixing screws.



Earth Pit

Used to allow access to the connection between the earth rod and conductor.

PLASTIC EARTH PIT

The lightweight, heavy duty inspection pit with its unique design has resulted in performance capabilities superior to the traditional concrete pit, at a similar cost. Manufactured from a high performance polymer, the pit is UV stable and chemical resistant. In addition, the features incorporated within its design ensure ease of storage, reduced transportation costs, ease of installation and ease of subsequent inspection and testing of the earth electrode system, therefore providing significant practical benefits to both installers and specifiers alike.

Features and benefits

- **Lockable jam free lid:**
Once installed the lid can be Allen Key locked to prevent tampering with equipment. Once locked, the design of the lid is such that debris cannot become jammed between the lid and the surround. Supplied with Allen Key.
- **Screw retention facility:**
The stainless steel, rustproof screws are snapped into the lid, preventing loss whilst in storage or on site. The screws may also be used to lift off the lid using special sockets.
- **Shatterproof material:**
The high performance polymer is significantly less brittle than concrete, reducing the likelihood of wastage due to breakages.

- **Chemical resistance:**
Resistant to most substances, including petrol, oil, diesel, bitumen and concrete.
- **UV Stability:**
UV additive minimising the effects of direct sunlight.
- **Wide temperature applications:**
Capable of withstanding a wide range of external temperatures.
- **Central 70mm diameter rod location hole:**
This ensures that the earth rod is centrally positioned, simplifying earth clamp connection.
- **Quality guarantee:**
Fully compliant to BS EN 62305-3 and tested to BS EN 62561-5.

Plastic

Part No.	Max Load (kg)
EIP-PL	5000

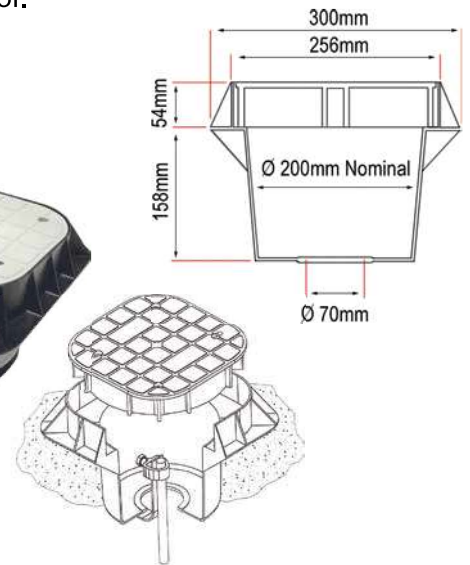

CONCRETE EARTH PIT

- **Suitable for most types of earthing and lightning protection installations**
- **The inspection pit protects the earth rod connection and makes it accessible for inspection**

Dimensions: 275mm (W) x 275mm (D) x 130mm (H)

Concrete

Part No.	Max Load (kg)
EIP-CON	4500

