

**Product Code:** CU2MS100

**Description:** 2 Pole 100A Mains Isolator Switch

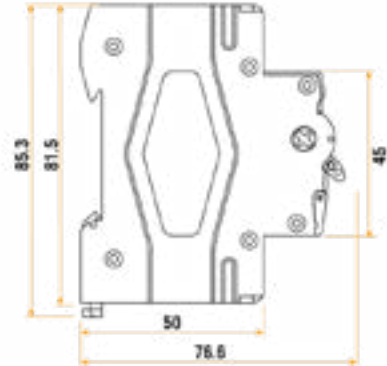

## General Information

Dimensions (mm)	35,9 (W) x 85,3 (H) x 76,6 (D)	
Finish	Light Grey (RAL 7035)	
Frequency (Hz)	50/60	
Maximum Rated Current (A) (In)	100	
Utilisation Category	AC-22A	
Rated Short Circuit Withstand Current (Icw)	12 Ie, t=1s	
Rated Short Circuit Making Capacity (Icm)	20 Ie	
Rated Making & Breaking Capacity	3Ie, 1.05Ue, COS Φ =0.65	
Rated Insulation Voltage (V) (Ui)	690	
Impulse Withstand Voltage (Uimp)	6000	
Endurance Mechanical Operations	10000	
Endurance Electrical Operations	1500	
Device Terminals	Screwed Lug & Pin	
Main Switch Terminal Capacity (mm <sup>2</sup> )	35	Main Switch Terminal Torque (Nm) 2,5
Number Of Poles	2	
Ingress Protection	IP20	
Operational Temperature (°C)	-25 to +40	
Warranty (Years)	3	

**Standards** BS EN 60947-3

**Additional Information** For cleaning / polishing of products, use only a soft, dry, clean cloth.