



REDRING POWERSTREAM

**UNVENTED INSTANTANEOUS
WATER HEATER**

Installation and User Guide

IMPORTANT:

**This booklet should be left with the user after
installation and demonstration.**

**It should be kept in a safe place, as you may need to
refer to it for general instructions or future
maintenance**

THIS APPLIANCE CAN BE USED BY CHILDREN AGED FROM 8 YEARS AND ABOVE AND PERSONS WITH REDUCED PHYSICAL, SENSORY OR MENTAL CAPABILITIES, OR LACK OF EXPERIENCE AND KNOWLEDGE IF THEY HAVE BEEN GIVEN SUPERVISION OR INSTRUCTION CONCERNING USE OF THE APPLIANCE IN A SAFE WAY AND UNDERSTAND THE HAZARDS INVOLVED.

CHILDREN SHALL NOT PLAY WITH THE APPLIANCE.

CLEANING AND USER MAINTENANCE SHALL NOT BE MADE BY CHILDREN

INTRODUCTION

Thank you for purchasing a quality *Redring Powerstream* manufactured in England.

To enjoy your new unit at its best, please take time to read this manual thoroughly to familiarise yourself with all instructions, BEFORE beginning installation.

If you experience any difficulty with the installation or operation of your new water heater, then please refer to the "What to do if things go wrong" section in this manual before contacting us.

IMPORTANT SAFETY INFORMATION

- Your *Powerstream* has been designed for convenience, economy and safety of use, provided that it is installed, used and maintained in good working order and in accordance with our instructions and recommendations.
- **ALL WIRING AND INSTALLATION MUST BE SUPERVISED BY A SUITABLY QUALIFIED PERSON.**
- **THIS APPLIANCE MUST BE EARTHED.**
- The installation must be in accordance with the current edition of BS.7671 (*the "IEE Wiring Regulations"*) and "Part P" of the "*Building Regulations*" in force at the time of installation. Installations outside England and Wales must also conform to any local regulations in effect.
- This appliance is intended to be permanently connected to the fixed electrical wiring of the mains supply with its own dedicated supply.
- Ensure that the mains water supply meets the requirements listed.
- **THIS APPLIANCE MUST NOT BE FITTED WHERE IT MAY BE SUBJECTED TO FREEZING CONDITIONS.**
DO NOT SWITCH THE APPLIANCE ON IF YOU SUSPECT IT OF BEING FROZEN. WAIT UNTIL YOU ARE SURE IT HAS THAWED OUT.
- **THE UNIT MUST NOT BE MOUNTED UPSIDE DOWN (diagram 1b).**
- **THE UNIT MUST NOT BE FITTED TO ANY TYPE OF THERMOSTATIC MIXER VALVE OR TAP.**
- If a non-return valve is fitted in the Inlet feed to the unit, then the installation should also include a 3.5 BAR Pressure Reducing Valve and a 6 BAR Pressure Relief (Expansion) Valve.
- **ISOLATE THE MAINS ELECTRICAL AND WATER SUPPLY BEFORE REMOVING APPLIANCE FRONT COVER.**

HOW TO INSTALL YOUR *POWERSTREAM*

WARNING: ALL WIRING AND INSTALLATION MUST BE SUPERVISED BY A SUITABLY QUALIFIED PERSON.

WARNING: DO NOT INSTALL WHERE IT MAY BE SUBJECTED TO FREEZING CONDITIONS.

Diagram 1a

Examples of fitted units

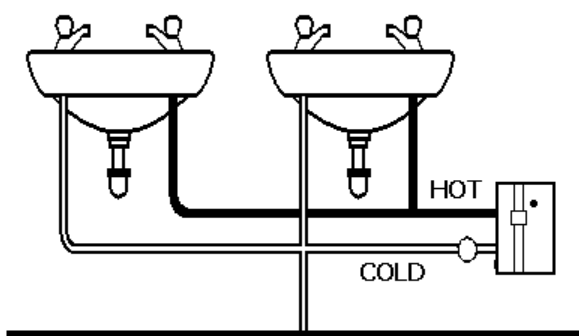
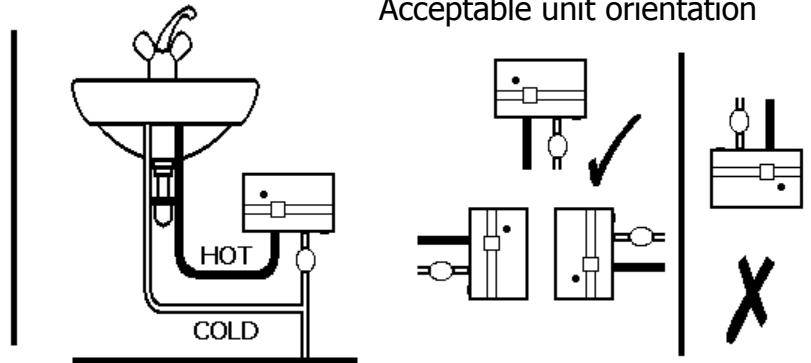

Diagram 1b

Acceptable unit orientation



The Powerstream is recommended to supply a **MAXIMUM** of two washbasins (see diagram 1a) **OR** a washbasin and shower (see diagram 4b)

If the Powerstream is connected to a mixer tap then only **NON-**Thermostatic types should be used (water mixes at the outlet pipe only).

The Powerstream is **NOT** to be fitted to a bath or kitchen sink other than for hand-washing purposes. (See Guarantee exclusions on page 12 and product flow rate tables on page 11).

The unit **MUST NOT** be mounted upside down (diagram 1b).

BEFORE YOU START

Check the unit rating plate to ensure the mains electric is capable of supplying the required current.

Check the pressure of the main water supply.

To operate correctly, the unit requires the following running pressures, check unit rating plate:-

Model	Dynamic Water Pressure			
	Basin		Shower	
	Minimum	Maximum	Minimum	Maximum
Up to 9.5kW	10 psi (0.7 bar) (69 kPa)	150 psi (10.3 bar) (1035 kPa)	15 psi (1.1 bar) (103 kPa)	150 psi (10.3 bar) (1035 kPa)
Up to 10.8kW	15 psi (1.1 bar) (103 kPa)	150 psi (10.3 bar) (1035 kPa)	20 psi (1.4 bar) (138 kPa)	150 psi (10.3 bar) (1035 kPa)
Up to 12.0kW	20 psi (1.4 bar) (138 kPa)	150 psi (10.3 bar) (1035 kPa)	25 psi (1.8 bar) (172 kPa)	150 psi (10.3 bar) (1035 kPa)

FIXING THE UNIT TO THE WALL

Deciding the position

- If being used in a public place, position the unit out of reach to discourage vandalism.
- Fit the unit onto a flat piece of wall, well away from any potential splashes of water or spray.
- Position the unit either upright or lengthways (diagram 1a/b), whichever is most convenient for plumbing and wiring, keeping the hot water pipe length to a minimum in order to save energy.
To maintain the integrity of the IPX4 Protection Rating, the unit MUST NOT be mounted upside down (diagram 1b)
- If the unit is to supply a basin, you can fit it either above or below the basin.

Deciding the wiring route

- You have a choice of whether to feed the electric cable through the side or through the back of the unit.
- If it going through the side of the unit, cut out the plastic lug to expose the grommet (diagram 2).
- If is going through the back of the unit, cut through the grommet on the backplate with a sharp knife (**Take Care!**). Make sure you do not remove the grommet from the backplate (diagram 3). Feed the cable through the grommet before you fix the unit to the wall.

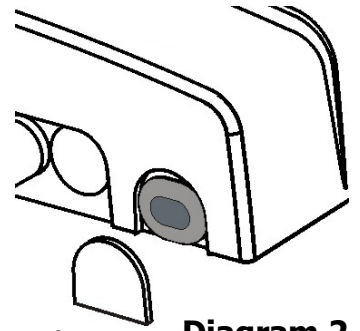

Diagram 2
Lug cut out

Fixing to the wall

- Undo the retaining nuts and take the front cover off the unit. Hold the backplate in position against the wall whilst you mark the four fixing holes.
- Drill the holes and fix the unit to the wall using the screws supplied.

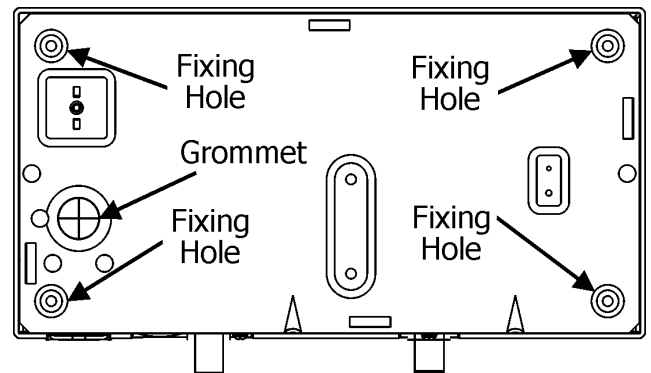

Diagram 3
Back of unit

Plumbing the unit

WARNING: IF A NON RETURN VALVE IS FITTED IN THE INLET FEED TO THE UNIT, THEN THE INSTALLATION SHOULD ALSO INCLUDE A 3.5 BAR PRESSURE REDUCING VALVE AND A 6 BAR PRESSURE RELIEF (EXPANSION) VALVE

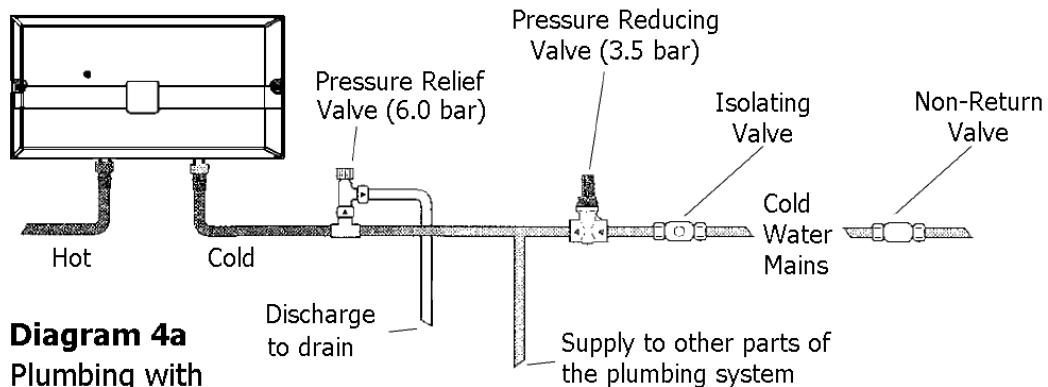

Diagram 4a
Plumbing with
Non-Return Valve

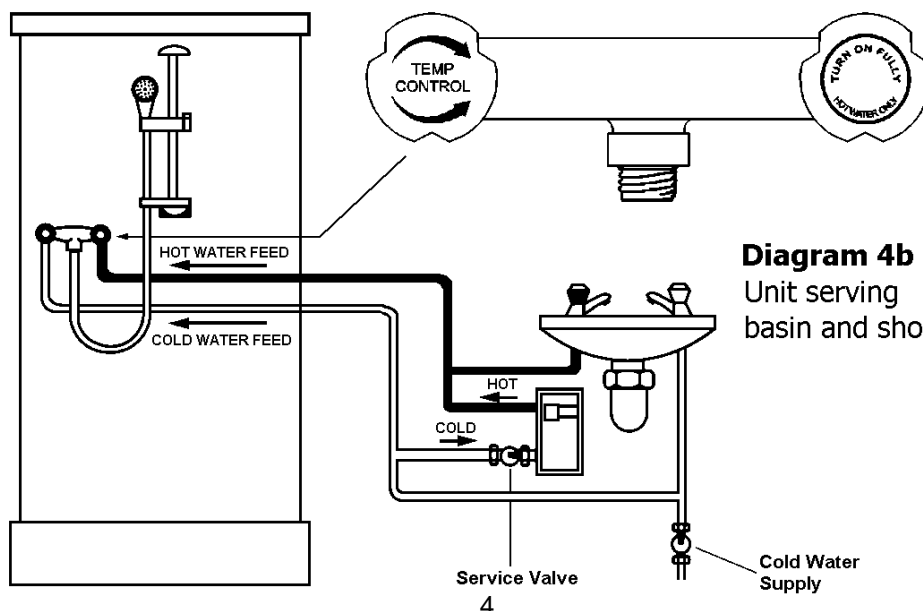

Diagram 4b
Unit serving
basin and shower

WARNING: ENSURE THAT THE MAINS WATER SUPPLY MEETS THE REQUIREMENTS LISTED ON PAGE 3 BEFORE CONTINUING WITH INSTALLATION.

WARNING: BEFORE CONNECTING THE PIPE WORK TO THE POWERSTREAM, ENSURE THAT THE PIPE WORK IS FULLY FLUSHED OUT.

Fitting the pipes

- The unit should be connected directly to the main cold water supply.
- We recommend that you use Ø15mm copper or stainless steel pipe for the inlet and outlet connections. (See addendum sheet for local installation requirements).
- Use PTFE tape for making screw joints. Do not use a jointing compound.
- Remember to keep the hot water pipe runs as short as possible.
- If the unit is to supply more than one basin outlet, the height should be the same at each outlet if they are to be used at the same time. If not, one outlet will take all the water.

In some cases, it may be worth fitting a second unit.

- When the pipework has been plumbed in, flush it through with water before you connect the unit, to remove any swarf or loose particles.

Connecting the unit to the pipes

- Model 45-793270: See addendum sheet for local installation requirements.
- The inlet and outlet are clearly marked on the unit. Some models are fitted with ½” NPT connections. Other models have Ø15mm straight shank connections.
- The unit comes with a service valve (diagram 5) which should be fitted on the inlet of the unit. Models have either ½” NPT connections or Ø15mm straight shanks. Check your unit to see which applies. The valve can be used to turn off the water supply to the unit if it needs servicing, or to reduce the main supply flow if it is too high (see “commissioning” section on page 7).

Fitting the attachments

- If the unit is to supply a shower, you will also need a “Redring Mixer Unit”. Available in chrome/white finish and suitable for surface or concealed pipe entry (see page 9 for details).
- If the unit is to supply a shower, and the shower handset can reach water in a bath or basin, you must fit a vacuum breaker to comply with Water By-laws. Alternatively, use the hose-retaining feature built into the soapdish.

Because water can sometimes seep through, you should position the vacuum breaker where dripping will not do any damage.

- If the unit is to supply a basin or two basins, we recommend that you use “¼ turn lever control spray taps” (see page 9).

Diagram 5

Service Valve supplied with:

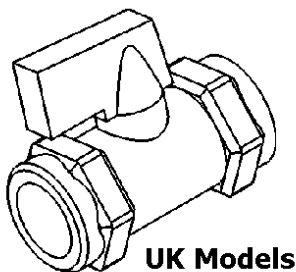

UK Models

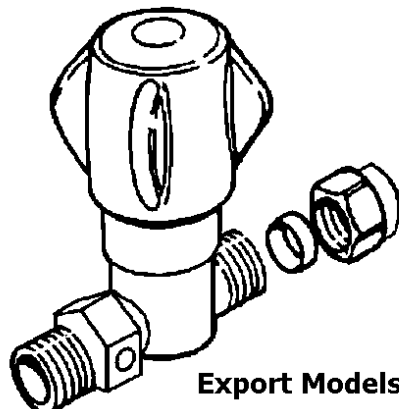

Export Models

This information shows how our products pass relevant European Union Energy Directives (ErP)

Manufacturer	Redring		
Product	RP1	RP10.8	RP12
Load Profile	XS	XS	XS
Efficiency Class	A	A	A
Efficiency %	39	39	39
Consumption (kWh / annum)	473	468	469
Sound (dB)	15	15	15
Precautions	<i>Ensure all product installation, maintenance and care instructions are followed as listed here</i>		

MAKING THE ELECTRICAL CONNECTIONS

WARNING: THIS WATER HEATER MUST BE EARTHED.

The electrical installation must be in accordance with the current BS.7671 (IEE Wiring Regulations) and "Part P" of the Building Regulations and/or local regulations

Wiring to the mains (Check the unit rating to see which applies)

Rating	Fuse/MCB	Isolating Switch	Cable Size
9.5 kW	40 amps	40 amps	6 mm ² / 10 mm ² *
10.8 kW	45 amps	45 amps	10 mm ²
12.0 kW	50 amps	50 amps	10 mm ² /16mm ² *

* For cable runs over 10 metres or where cable is not flat clipped and surface mounted, the larger size is the minimum required.

A means for disconnection in all poles must be incorporated in the fixed wiring in accordance with the wiring rules.

If the unit is fitted in a Bathroom:

9.5 kW and 10.8 kW Powerstream: A standard 45 amp cord operated isolator switch is recommended.

12.0 kW Powerstream: A double pole 50 amp isolator switch is required.

This must be mounted out of reach of the shower cubicle or bath.

Wiring the Powerstream

- The unit has been designed to accept up to 16mm² supply cable. It will be necessary to cut the rubber entry grommet (diagram 6, point X to X) to enable 10mm² and 16mm² to be correctly installed. No cutting is required for 6mm² cable. In all cases the outer sheath of the cable **MUST** project through the grommet (diagram 6), if side entry is used. This will prevent water getting into the unit.
- Strip back the insulation on the **LIVE** (brown or red) and **NEUTRAL** (blue or black) mains wires about 8mm. Strip back any insulation on the **EARTH** (green/yellow or green) about 20mm.
- Feed the cable through the side or rear entry grommets, as appropriate.
- Connect the cables to the terminal block and earth stud (diagram 6)
- Make sure that the live and neutral terminal block screws are tightened securely (1Nm minimum)
- Make sure that the earth wire is wrapped around its terminal stud and into the saddle washer. The nut should be tightened securely (2Nm minimum).

WARNING: FAILURE TO COMPLY WITH THESE INSTRUCTIONS COULD RESULT IN FAILURE OF THE TERMINAL BLOCK

- Check that the Power Selector Screw on the flow switch is set to "HI" (diagram 7). If flow switch is set to "LO" only one heater element will operate.
- Fit the front cover and tighten the retaining nuts.

Ensuring the earth continuity

- If the unit is fitted in a bathroom, to conform with the current BS.7671 (formally IEE regulations), the units earth continuity conductor must be effectively connected to **ALL** exposed metal parts of **ALL** other appliances in the room.

COMMISSIONING YOUR *POWERSTREAM*

CHECKING FOR LEAKS

- Let the water run through the unit for a few seconds. Close the outlet and check that no pipe joints leak.

ADJUSTING THE SERVICE VALVE

- If the unit is to supply a basin,
 - turn on the hot water tap fully at the basin.
 - turn the service valve on slowly until the neon illuminates on the product (max temperature).
 - adjust the service valve until the water comes out of the tap at the required temperature. allowing for the temperature of the water to settle after each adjustment
 - check that the unit works correctly when the basin tap is closed and then opened again: if not, adjust the service valve slightly.
- If the unit is to supply a shower,
 - turn the hot water tap on the mixer unit fully on.
 - turn the service valve clockwise until the neon light goes out, then turn it back until the neon just comes on.
 - check the water temperature at the handset and, if necessary, turn the cold tap on and adjust to get the desired shower temperature.

WARNING: YOU MUST REGULARLY INSPECT THE SHOWER HOSE FOR WEAR AND DAMAGE. REPLACE IF NECESSARY, OR EVERY TWO YEARS, WITH OUR APPROVED PART.

WARNING: TO MAINTAIN THE PERFORMANCE OF YOUR SHOWER, YOU MUST DESCALE THE SHOWER HANDSET REGULARLY.

All water contains particles of lime-scale, which build up in the shower handset and unit reducing the performance.

It is therefore important to clean the shower handset by simply rubbing the rubber nozzles, or soaking in proprietary lime-scale remover and rinsing thoroughly before use.

The frequency of this will depend on water hardness and experience.

Explain to the user that when the unit is used, the hot water tap should be turned fully on so that the unit will operate correctly.

Diagram 6

Cable termination

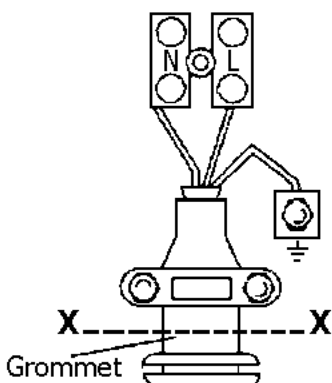

Diagram 7

Power selector screw

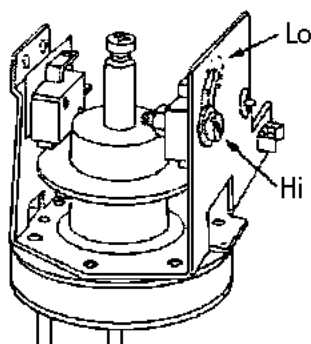
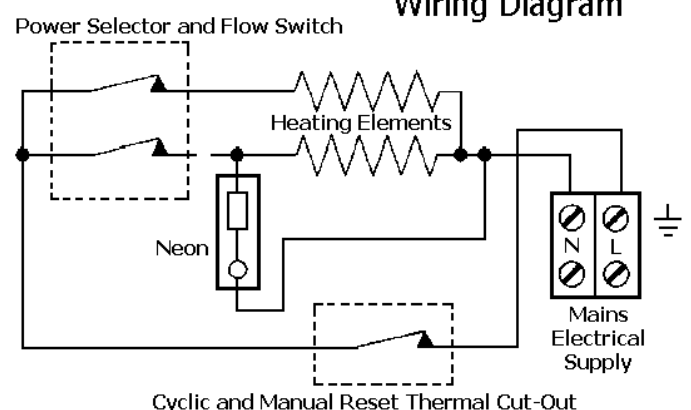

Diagram 8

Wiring Diagram



HOW TO USE YOUR *POWERSTREAM*

WARNING: DO NOT USE THE UNIT IF YOU THINK IT MAY BE FROZEN, AS THIS COULD RESULT IN SERIOUS DAMAGE TO THE UNIT. WAIT UNTIL YOU ARE SURE THAT IT HAS COMPLETELY THAWED OUT BEFORE YOU SWITCH ON.

Basin

- Check that the power is switched on at the mains isolator switch.
- Turn on the hot water tap **FULLY**. If you do not turn the tap on, you will find that the temperature of the water will vary. The hot water temperature will have been set using the service valve (diagram 5).
- If the unit has been used recently, run the water through for a few seconds to let the temperature settle down, we advise you **DO NOT** enter the water flow during this time.
WARNING: YOU MAY INITIALLY GET A SHORT BURST OF VERY HOT WATER FROM THE UNIT.
- If a second tap connected to the unit is also turned on, the hot water will be shared between the two and so the flow will drop.
- When you have finished do not switch off the power if you are going to use the unit again shortly.

Shower

- Check that the power is switched on at the mains local isolator switch.
- Turn on the hot (or "flow") tap **FULLY** (diagram 9).
- If the unit has been used recently, run the water through for a few seconds to let the temperature settle down, we advise you **DO NOT** enter the water flow during this time.
WARNING: YOU MAY INITIALLY GET A SHORT BURST OF VERY HOT WATER FROM THE UNIT.
- Turn on the cold (or "temperature") tap, if necessary, to adjust the temperature of the water.
- Make sure that no other outlets connected to the unit are used whilst you are in the shower, or the water flow will drop suddenly.
- When you have finished, do not switch off the power if you are going to use the unit again shortly.
- It is important to clean the shower spray plate regularly (see page 7).
- In order for the Powerstream to function correctly, the "Redring Mixer Kit" must be used. The kit, Cat No. 85-793620, comes complete with full accessories including a 3 position multi-function shower handset.

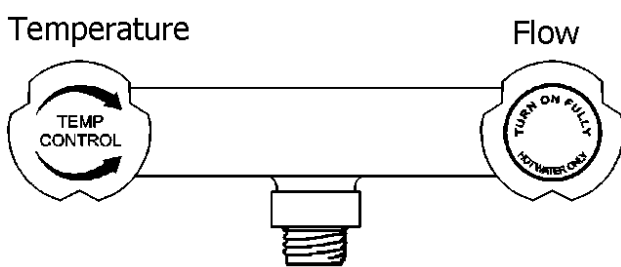

Diagram 9
Mixer Units

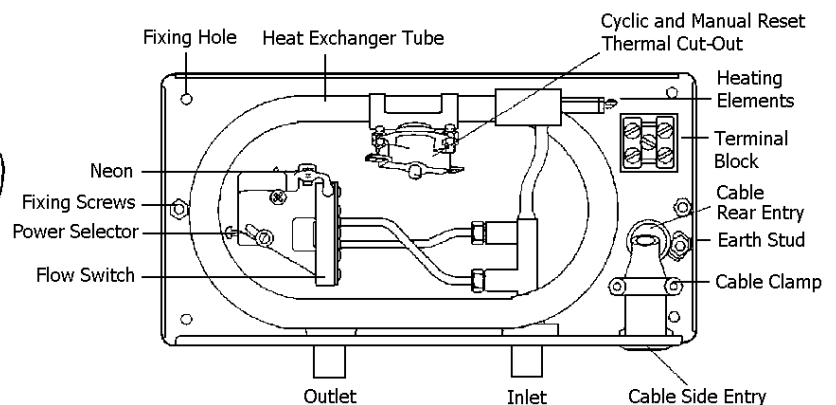

Diagram 10
Inside View

WHAT TO DO IF THINGS GO WRONG (1)

SELF HELP

If the unit is not working satisfactorily, make the following checks before calling out the installer. Any one of these adjustments could restore the performance.

Symptom	Cause	What to do
Little or no water flow.	The main water supply is turned off.	Turn on the main supply fully at the stop valve. Set up unit as per commissioning instructions.
Cold water only - neon light off.	The main water supply is not turned on enough.	Turn on the main supply fully at the stop valve.
Water too cold - neon light on.	The water flow rate is too high. The inlet water temperature has dropped.	Adjust the service valve (see page 7). Adjust the service valve (see page 7). For a shower, adjust the spray pattern available on the multi-mode handset.
Water flow too low, or temperature too high.	The main water supply is too low The hot tap is not fully open.	Increase the supply water flow. Make sure that the service valve is correctly adjusted. Adjust the service valve so that the water is at the right temperature with the tap fully open (see page 7). Always turn the hot tap fully on.
Water goes from hot to cold.	The water flow or pressure is too low, and the thermal cut-out is operating. A second outlet has been turned on.	Increase the supply water flow Make sure that the service valve is correctly adjusted. Do not use the basin whilst using the shower.
Shower spray pattern deteriorates.	The shower handset is clogged.	Clean the handset using a descaling solution if required (see page 9).

REDRING AFTER SALES SERVICE

We offer a technical advisory service on the telephone to installers and other customers with problems in the field.

Ring 0344 8793588 (UK ONLY) / Ring your Local Dealer (Export Variants)

Or alternatively email us on: Customer.services@glendimplex.com

Remember to quote the exact type of unit, as written on the front of the unit and on this leaflet.

The model and serial number are located on the bottom face of the unit.

Make a note of those numbers here, and be sure to quote them if you call for advice.

Model Number: _____ **Serial Number:** _____

Note: You may be charged for a service call if you do not have the serial number.

ADDITIONAL ACCESSORIES AND COMMON SPARE PARTS

Please Note:- The fitting of Spare Parts must be supervised by a suitably qualified person.

Chrome and White shower mixer unit complete with full accessories

Including 3 position multi-function handset

¼ turn lever control spray tap

Catalogue No. 85-793620

Catalogue No. 85-793616

For further details, including a comprehensive list of accessories and spare parts, contact Redring Sales Hotline 0344 879 3588

WHAT TO DO IF THINGS GO WRONG (2)

PROFESSIONAL SERVICE

If the previous "Self Help" checks fail to restore the performance, you should seek professional help. The person who installed the shower is probably the best one to investigate and correct it and is certainly the person to contact if you have had a problem in the guarantee period.

The following additional checklist is provided for the benefit of the qualified service person.

WARNING: SWITCH OFF THE ELECTRICITY AT THE LOCAL ISOLATOR BEFORE REMOVING THE COVER TO MAKE CHECKS

Symptom	Cause	What to do								
Little or no water flows - neon light off.	The water pressure is very low.	Use a pump to boost the supply from a storage tank.								
Cold water only - neon light off.	The main water is connected to the OUTLET of the unit. The water pressure is too low. The thermal cut-out has triggered. The flow switch is not working.	Reconnect the main supply to the INLET (marked in blue). Use a pump to boost the supply from a storage tank. Reset it by opening the unit and pushing the button on the cut-out (diagram 11). Before you do this you must remove the cause of the problem. Contact Redring (see page 9).								
Water too cold - neon light on.	The power select screw is set to "LO". One element is not working. The Power Supply Voltage has dropped.	Change the power select screw to "HI" (diagram 7). Switch off the electricity supply and check the resistance of the elements. You should get the following readings. <table style="margin-left: 20px;"> <tr> <td>Loading (kW)</td> <td>Resistance (Ohms)</td> </tr> <tr> <td>9.5</td> <td>12.0</td> </tr> <tr> <td>10.8</td> <td>10.6</td> </tr> <tr> <td>12.0</td> <td>9.6</td> </tr> </table> The heater should only draw the following currents: 40 amps for the 9.5kW model 45 amps for the 10.8kW model 50 amps for the 12.0kW model	Loading (kW)	Resistance (Ohms)	9.5	12.0	10.8	10.6	12.0	9.6
Loading (kW)	Resistance (Ohms)									
9.5	12.0									
10.8	10.6									
12.0	9.6									
Water flow too low or temperature too high	The service valve is fitted to the OUTLET. There are constrictions in the plumbing.	Fit the service valve to the INLET of the unit. Check the plumbing. Only use PTFE tape for making pipe joints.								
Water goes from hot to cold	The service valve is fitted to the OUTLET.	Fit the service valve to the INLET of the unit.								

HOW YOUR *POWERSTREAM* WORKS

Water comes in through the inlet, via a flow switch.

The flow switch measures how much water is passing through the unit.

If it detects more than the preset level of:-

2.7 litres/minute for the 9.5kW model and 3.3 litres/minute for the 10.8kW and 12.0kW models

The units heating elements are switched on. This is shown by the neon light glowing.

The water is heated instantly as it passes through the copper heat exchanger tube.

The temperature of the water coming out of the unit depends on:-

- The temperature of the mains water supply
- The water flow rate
- The power consumption of the unit

The temperature of the main supply can vary from 5°C in winter up to about 20°C in summer, with an average of about 12°C. The charts below show the water temperature (°C) you can expect from the unit, operating at 9.5/10.8/12.0kW for the different flow rates (in litres/minute)

9.5kW Powerstream

Flow rate (l/m)	3.0	4.0	6.0
Summer temp °C	–	54°	43°
Winter temp °C	50°	39°	28°

On average
(12°C main water supply at 4 litres/minute)
an outlet temperature of 46°C will be achieved.

10.8kW Powerstream

Flow rate (l/m)	4.0	5.0	6.0
Summer temp °C	–	51°	46°
Winter temp °C	44°	36°	31°

On average
(12°C main water supply at 5 litres/minute) an
outlet temperature of 43°C will be achieved.

12.0kW Powerstream

Flow rate (l/m)	5.0	6.0	7.0
Summer temp °C	54°	49°	44°
Winter temp °C	39°	34°	30°

On average
(12°C main water supply at 6 litres/minute) an
outlet temperature of 41°C will be achieved.

This means that with the 12.0kW unit you can shower at 39°C with a flow rate of 5 litres/minute in the middle of winter.

The unit includes a dual thermal cut-out (diagram 11) which is attached to the heat exchanger tube. It will switch off the heater elements if the water flow is reduced too much and the temperature goes above a set limit.

The first stage cut-out is cyclic and will automatically reset as the water temperature falls. The unit will then function normally again.

The second stage cut-out when triggered needs to be reset manually inside the unit. This cut-out will only operate in exceptional circumstances (diagram 11)

The unit can supply two outlets – for example, a shower and a basin, or up to two basins – but water from the unit will be shared between the outlets. This is particularly important if a unit supplies a shower and a basin, as the basin should not be used while someone is using the shower. The unit is NOT to be fitted to a bath or kitchen sink other than for hand-washing purposes.

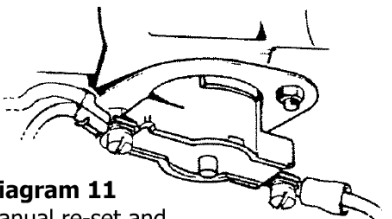

Diagram 11
Manual re-set and
Cyclic Thermal Cut-Out

UK only:
Redring products deliver reliable service for normal, household use in domestic settings. All Redring products are individually tested before leaving the factory.

If you are a consumer and you experience a problem with your Redring product, which is found to be defective due to faulty materials and workmanship within the warranty period, This Redring warranty will cover repair or at the discretion of Redring replacement with a functionally equivalent Redring Product.

The Redring warranty period is Two calendar years from the date of purchase of your Redring product, or the date of delivery of the product, if later. The Redring warranty is conditional upon you providing the original purchase receipt proof of purchase. Please therefore retain your receipt as proof of purchase.

If you do experience a problem with your Redring product please call the helpline on +44 (0)344 879 3588 or at the address below. We will need details of your Redring product, and a description of the fault which has occurred. Once we receive your information and proof of purchase we will contact you to make the necessary arrangements.

Customers outside UK - See International below.

If your Redring product is not covered by this Redring warranty there may be a charge to repair your product. However, we will contact you for an agreement to any charges before any chargeable service is carried out.

What is not covered by an Redring warranty?

The Redring warranty does not cover any of the following:

Any fault or damage to your Redring product due to faulty materials or workmanship occurring outside the Two year warranty Period.

Any fault or damage occurring to any pre-owned Redring product or to any other equipment or property.

Accidental damage to your Redring product or damage to your Redring product from external sources (for example, transit, weather, electrical outages or power surges).

Fault or damage to your Redring product which is:

Not due to faulty materials or workmanship or which is due to circumstances outside Redrings control.

Caused by use of your Redring product for anything other than normal domestic household purposes in the country where it was purchased.

Caused by any misuse, abuse or neglect use of the Redring product, including but not limited to any failure to use it in accordance with the Operating Instructions supplied with the product.

Caused by any failure to assemble, install, clean and maintain your Redring product in accordance with th Operating Instructions supplied with the product unless this was carried out by Redring or its authorised dealers.

Caused by repairs or alterations to your Redring product not carried out by Redring service personnel or its authorised dealer(s).

Caused by use of any consumables or spare parts for your Redring product which are not Redring specified.

Terms and Conditions

The Redring warranty is valid for Redring from the date of purchase of your Redring product from a recognised retailer in the country of purchase and use, or the date of delivery of the product if later, always provided the original receipt has been retained and is produced as proof of purchase.

You must provide to Redring or its authorised agents on request the original receipt as proof of purchase and - if required by Redring - proof of delivery. If you are unable to provide this documentation, you will be required to pay for any repair work required.

Any repair work under the Redring warranty will be carried out by Redring or its authorised dealer(s) and any parts that are replaced will become the property of Redring. Any repairs performed under the Redring warranty will not extend the warranty period.

Any replacement of your Redring product by Redring during the warranty period will start the Two year warranty period afresh from the date of delivery of the replacement Redring product to you.

The Redring warranty does not entitle you to recover of any indirect or consequential loss or damage including but not limited to loss or damage to any other property.

The Redring warranty is in addition to your statutory rights as a consumer and your statutory rights are not affected by this Redring warranty.

Contact Redring

If you have any questions about what the Redring warranty covers and does not cover or how to claim under Redring warranty, please contact us using the information below.

Contact details

Millbrook House, Grange Drive, Hedge End, Southampton, SO30 2DF

Telephone: +44 (0) 344 879 3588

Email: Customer.services@glendimplex.com

<http://www.redring.co.uk>

Glen Dimplex Europe Limited

Airport Road, Cloghran,

Co. Dublin, K67 VE08, Ireland

ROI Telephone: +353(0)1 842 833

Email: serviceireland@glendimplex.com

International

Warranty: Contact your local distributor or Redring direct for details.

Technical advice and service: Contact your local Redring distributor.

Redring: A brand of GDC Group Limited, trading as Glen Dimplex Heating & Ventilation

© Glen Dimplex. All rights reserved. Material contained in this publication may not be reproduced in whole or in part, without prior permission in writing of Glen Dimplex



For electrical products sold within the European Community. At the end of the electrical products useful life it should not be disposed of with household waste. Please recycle where facilities exist. Check with a Local Authority or retailer for recycling advice in your country. Batteries should be disposed of or recycled in accordance with WEEE Directive 2012/EU. Packaging should be recycled where possible.



FM02118 ISO 9001: 2000