

PRODUCT DATA SHEET

PART No. PPIT-G

DESCRIPTION: Plastic Inspection Pit



KINGSMILL
INDUSTRIES (UK) LTD

SPECIFICATION

PART No.	PPIT-G
DESCRIPTION	Plastic Inspection Pit
WEIGHT	1.28 kg
MATERIAL	Polypropylene
SOFTENING POINT	149 °C
LOAD RATING	≤ 5000 kg (Subject to Installation)
PIT DIMENSIONS	220 x 250 x 220 (mm) (W x D x H)

GENERAL ARRANGEMENT

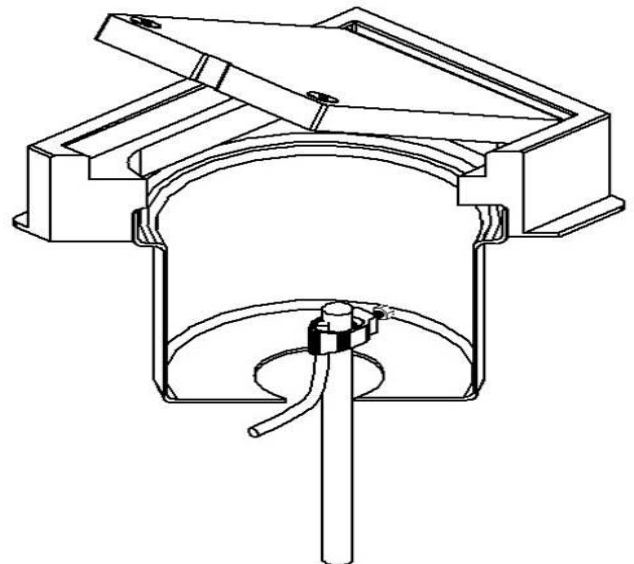

AUTHORISATION

AUTHOR:	<i>mgoodwin</i>	DATE:	06 / 02 / 2014
Approved	<i>[Signature]</i>	Date	07/02/2014

THIS DATA SHEET IS THE PROPERTY OF KINGSMILL INDUSTRIES (UK) LTD

KINGSMILL
INDUSTRIES (UK) LTD

UNIT 4, PLYMOUTH AVENUE, PINXTON, NG16 6NS, ENGLAND

TEL: +44 (0) 1773 510001 FAX: +44 (0) 1773 863336

E-MAIL: sales@kingsmillearthing.co.uk WEB: www.kingsmillearthing.co.uk