

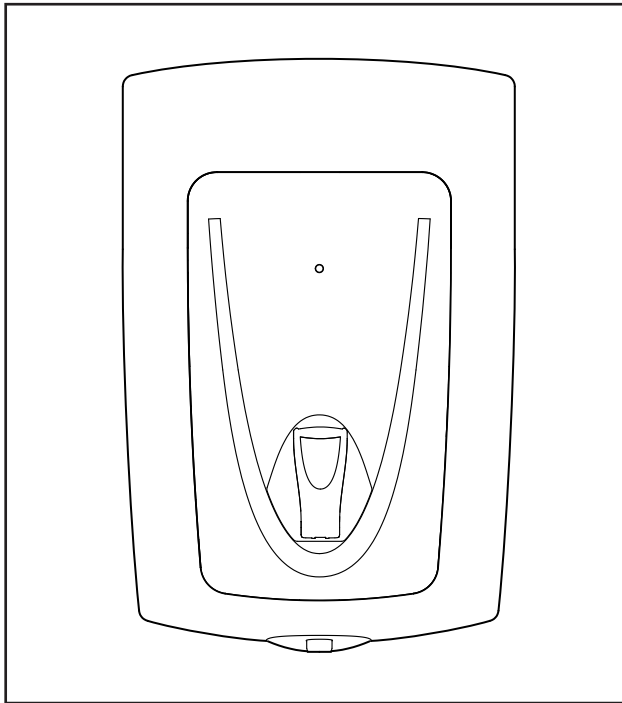

# Elson 2.5 litre Boiling Water Dispenser

Installation and User Instructions

Model: EBW25



Please read and understand these instructions before starting work.  
Please leave this leaflet with the user following installation.

## **WARNING**

This boiling water heater must only be installed by qualified persons.

## **PACK CONTENTS**

Heater, fixing screws and plugs, installation and user instructions.

36006232 Issue 6.

## INTRODUCTION

Thank you for purchasing an Elson EBW25. The boiling water heater is manufactured to the highest standards and has been designed to meet all the latest relevant safety specifications.

This Elson water heater must be installed (Sections 1-5, p.1-8), commissioned (Section 6, p.9) and maintained (Sections 7-8, p.7-11) by a competent person. Please read and understand these instructions prior to installing your Elson water heater. Following installation and commissioning the operation of the heater should be explained to the user (Section 10, p.14) and these instructions left with them for future reference.

This appliance can be used by children aged from 8 years and above if they have been given supervision or instruction concerning use of the appliance in a safe way and if they understand the hazards involved. Cleaning and user maintenance shall not be made by children unless they are older than 8 and supervised. Keep the appliance and its cord out of reach of children aged less than 8 years.

Appliances can be used by persons with reduced physical, sensory or mental capabilities or lack of experience and knowledge if they have been given supervision or instruction concerning use of the appliance in a safe way and understand the hazards involved.

## COMPONENT CHECKLIST

Before commencing installation check that all the following components have been supplied with your Elson heater.

- Wall mounting bracket
- No.12 x 2" screws (2 off)
- No.8 x 1" screw (1 off)
- No.12 x 2" wall plug (2 off)
- No.8 x 1" wall plug (1 off)
- 15mm x 15mm straight push-fit connector (fitted)
- 15mm x 15mm 90 ° elbow push fit connector (fitted)

## TECHNICAL SPECIFICATION

### CONNECTIONS

Inlet connection -15mm ext. diameter

Water entry point - bottom and rear

Cable entry point - bottom and rear

### ELECTRICAL

Model numbers

**2.5kW - Elson EBW25 - 93 200 001**

Electrical rating	2.3/2.5kW@230/240V	
Nominal capacities	Model EBW25	2.5 litres
Weight (full)	Model EBW25	8.4kg

Rated pressure

Minimum supply pressure 0.05MPa (0.5 bar)

Maximum supply pressure 1.0MPa (10 bar)

Enclosure rated IP X2

Nominal commissioning times (minutes) to temperature ready

Model EBW25 16

### STANDARDS AND APPROVALS

Complies with the requirement of EN 60335-2-35.

Nemko approved for electrical safety.

Complies with European Community Directives (CE).

Complies with UK water regulations, kiwa approved.

## 1.0 IMPORTANT INSTALLATION POINTS

- 1.1 The Elson EBW25 stores and dispenses water at or close to boiling point at all times it is switched on. Due caution must be taken when choosing a location for the product to minimise misuse. Locate the unit over a draining board NOT over the sink or basin.
- 1.2 Push fit connectors DO NOT grip chromed or stainless pipe.
- 1.3 The EBW25 is a vented water heater. The vent pipe must never be blocked or obstructed, it must be a minimum of 15mm outside diameter pipe. Where the vent pipe length exceeds 3m the pipe diameter should be increased. The vent pipe must be laid to a continuous fall and discharge in a safe and visible position; it must discharge via a tundish or finish a minimum of 20mm above a draining board. The vent pipe material must be capable of conveying boiling water. The vent pipe must never be connected directly to a soil pipe.
- 1.4 Wherever possible the EBW25 should be supplied directly from a rising main. If fed from a cold water feed cistern, the cistern must comply with the Water Regulations Guide (clause R27.2). It should be noted that water quality may be reduced when supplied from a cistern and additional forms of water pretreatment may be necessary.
- 1.5 In hard water areas, heated water will produce lime scale which will be deposited within the heater. If this is not regularly removed it will impair the operation of the heater. Where rapid and excessive scale build up is likely to occur the use of a proprietary scale reducing device may be beneficial.
- 1.6 **The installation must be carried out in accordance with the relevant requirements of:**
  - The appropriate Building Regulations either The Building Regulations (England & Wales), The Building Regulations (Scotland) or Building Regulations (Northern Ireland).
  - The Water Fittings Regulations or Water Byelaws in Scotland.
- 1.7 The EBW25 will adjust for ambient (room) temperatures of between 1°C and 40°C.
- 1.8 When not in use care must be taken to prevent it freezing; if thought to be frozen it must not be switched on. It must be left to thaw and must then be thoroughly inspected to ensure it is totally thawed and undamaged.
- 1.9 The unit is not suitable for installation in an area where a water jet could be used.

## 2.0 INSTALLATION - MOUNTING

- 2.1 The EBW25 must be vertically wall mounted using the bracket supplied.
- 2.2 Figure.1 (p.6) details the outside dimensions of the EBW25 unit. It is recommended that the unit is positioned above the draining board. If this is not possible consideration should be given to any spillages that may occur under the appliance. The heater should be positioned at a height to suit the items being filled (flasks, pans, cups etc.). This is likely to position the base of the unit 250mm above the work surface.
- 2.3 Sufficient room should be left around the heater for access for maintenance and servicing. The top should not be covered as this will reduce the efficiency of the EBW25.
- 2.4 Ensure that the wall can support the full weight of the unit (see TECHNICAL SPECIFICATIONS, p.3) and that there are no hidden services (electricity, gas or water) below the surface of the wall.
- 2.5 Using the backplate mark the fixing positions and water and vent entry points. Drill and plug the fixing positions. Fix the mounting bracket to the wall using the two No. 12x2" screws provided (confirm suitability of all screws and plugs for use with the wall, if unsuitable due to wall type provide alternative fixings)
- 2.6 If rear entry services are to be used the necessary holes for these should be prepared prior to hanging the unit onto its bracket.
- 2.7 Remove the front cover by unscrewing the top and bottom cover fixing screws bottom and top. Hang the EBW25 onto the wall mounting bracket. Secure anchor point to the wall with the No.8 x 1" screw (provided).

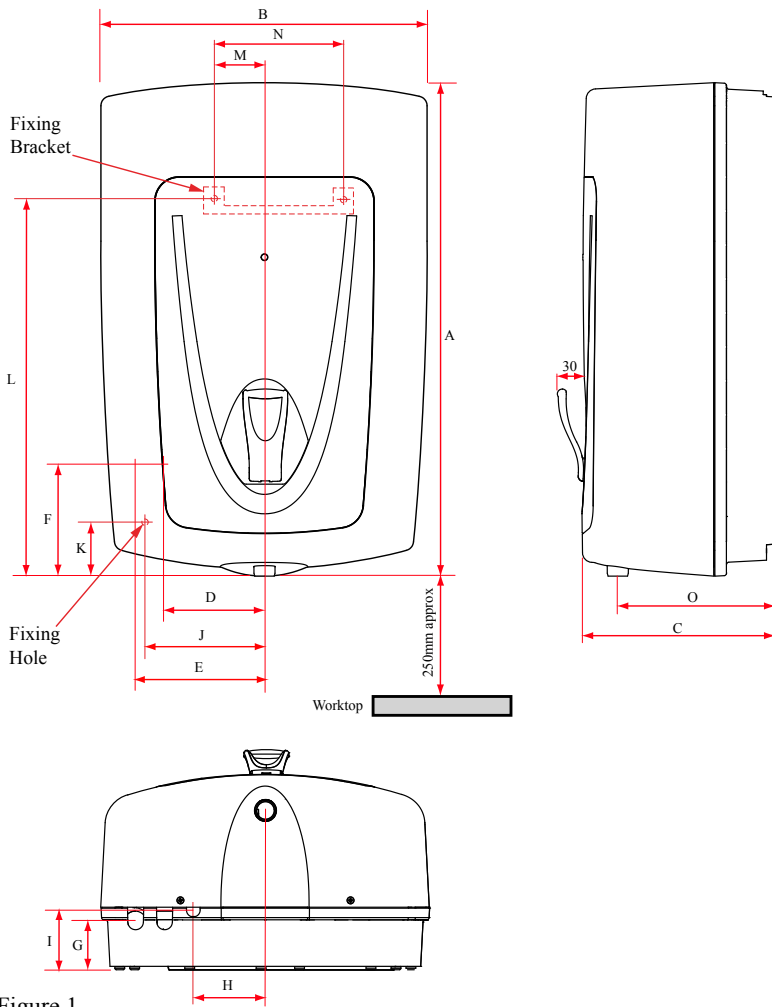

Figure 1

MODEL	DIMENSIONS (mm)							
	A	B	C	D	E	F	G	H
				INLET	VENT	INLET/ VENT	INLET/ VENT	CABLE ENTRY
EBW25	445	290	190	85	115	101	49	46

	I	J	K	L	M	N	O
	CABLE ENTRY	FIXING POINT	FIXING POINT	BRACKET	BRACKET	BRACKET	OUTLET
EBW25	59	96	50	342	52.5	169	152

### 3.0 INSTALLATION - WATER SUPPLY

- 3.1 Select appropriate push fit connector for chosen entry position:  
Bottom entry water - 15mm x 15mm 90° elbow.  
Rear entry water- 15mm x 15mm straight.  
**Note:** Stainless or chromed pipes DO NOT provide secure connections with push fit fittings (use copper pipe at joints).
- 3.2 Push the connector fully home (28mm engagement) onto the solenoid valve inlet spigot. To remove a push fit connector the collar (collet) should be pushed towards the body of the fitting whilst pulling the connector off the pipe.
- 3.3 If the inlet pipe run is horizontal and beneath the unit ensure it does not prevent access to the case screws.
- 3.4 Connect the inlet pipe to the push fit connector ensuring it is fully pushed home (28mm engagement). After connection DO NOT make soldered joints in the pipe work close to the heater, as the heat may damage the connector or the water heater itself.
- 3.5 A WRAS listed isolating valve should be fitted to the cold supply to facilitate servicing the heater.
- 3.6 Push fit connectors are supplied to allow either bottom or rear entry of services.

### 4.0 INSTALLATION - VENT PIPE

- 4.1 Select appropriate push fit connector for chosen entry position:  
Bottom entry vent - 15mm x 15mm straight  
Rear entry vent - 15mm x 15mm 90° elbow
- 4.2 Push the connector fully home (28mm engagement) onto the vent pipe connection.
- 4.3 Connect the vent pipe to the push fit connector ensuring it is pushed fully home (28mm engagement). Refer to the vent pipe requirement detailed in IMPORTANT INSTALLATION POINTS (p.4). If a bottom entry vent pipe is used the pipe must terminate below the unit, in a safe visible position. After connection DO NOT make soldered joints in the pipe work close to the heater, as the heat may damage the connector or the water heater itself.

## 5.0 INSTALLATION - ELECTRICAL REQUIREMENTS

### WARNING:

- 5.1 This appliance must be earthed.
- 5.2 The installation, supply cable and circuit protection must conform to the latest BS7671 'Requirements for electrical installations' (IEE Wiring Regulations).
- 5.3 The appliance must only be connected to a 230/240 V ac supply. A double pole isolating switch, with a contact separation of at least 3mm in each pole, must be incorporated in the electrical supply. The supply should be fused 13Amp.
- 5.4 If the EBW25 is to be unused for significant periods of time running costs can be reduced by switching the unit off. It is recommended that this is done automatically by incorporating a suitable timeswitch in the supply to the unit. The use of accessory no. 95 970 124 is recommended. The timeswitch can then be set to switch the unit on for a suitable period to allow it to heat up before it is next to be used. **Note:** A timeswitch must be capable of switching 13 Amps resistive load.

Figure 2: Wiring Diagram (2.5kW)

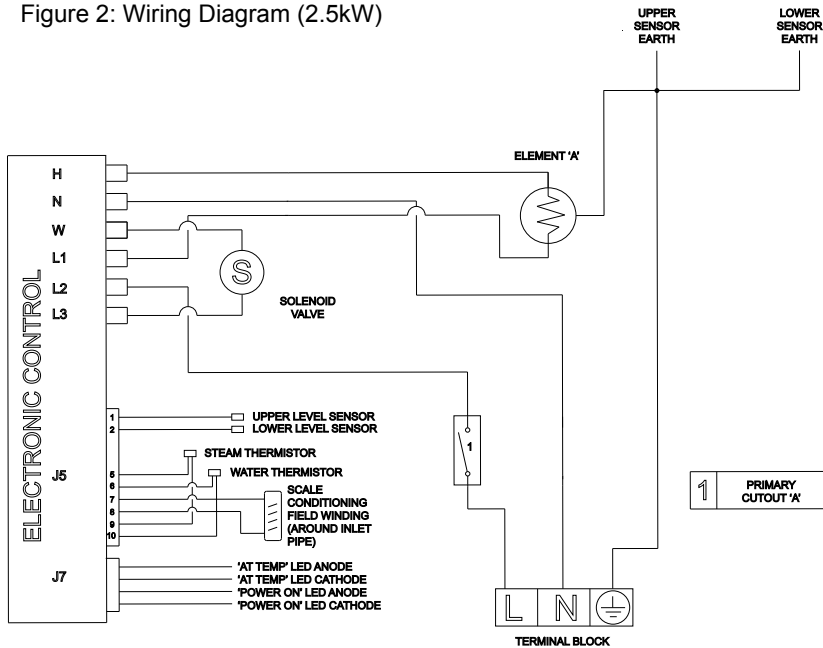



## 6.0 COMMISSIONING

- 6.1 The electronic control system of the EBW25 has a self commissioning and calibration function. Once the heater is installed and all services have been connected the appliance should require no further adjustment before use.
- 6.2 Check that all electrical, water and vent pipe connections have been made and are secure.
- 6.3 Replace the cover and secure with the fixing screws. Ensure the tank discharge tube is centrally located in the outlet spout. Turn on the water then the electrical supply.
- 6.4 The LED indicator will flash to indicate the unit is in its "self commissioning" mode. The water in the unit will not be hot enough to use at this stage (do not draw water off).
- 6.5 The LED indicator will continue to flash until the unit has reached boiling and has "self-calibrated". At this point the LED indicator will remain illuminated. If for any reason the calibration procedure is interrupted it will restart after a short delay but may result in the calibrated temperature being too low. If this occurs switch the electrical supply OFF for several seconds and then switch ON. The calibration sequence will reset. Wait for the LED indicator to remain illuminated.
- 6.6 The unit is now ready to use, however, it is recommended that the first few fills be drawn off and discarded to ensure the freshness of the water.
- 6.7 The tap sealing washer pressure has been already set. If the tap drips after commissioning adjust the spring tension so that the handle is just loose.
  - a) Remove the tap bezel after removing the two screws securing it.

**Note:** To remove the bezel the handle will have to be operated. This will cause water to discharge from the outlet (see Page 13, item 9).
  - b) Tighten the tap headwork nut (turn clockwise) until the handle is just loose. Replace bezel and securing screws.

**Note:** Excessive adjustment will dismantle the tap, if heated this would result in the uncontrollable release of boiling water (see Page 13, item 7).
- 6.8 Check for leaks.
- 6.9 **IMPORTANT NOTE:** Each time the unit is switched off then switched on it will always go through the same cycle 6.4-6.5. Water should never be drawn off the unit until commissioning is complete and the LED indicator remains constant.

## 7.0 MAINTENANCE

**Note:** Maintenance must be carried out by competent persons.

Competent - i.e. Trained, experienced, qualified.

Disconnect the electrical supply before removing the cover.

**WARNING:** Electronics control by switching 'n' (neutral), in some instances neutral terminations will be at 230 volts with respect to earth.

- 7.1 The EBW25 incorporates an electronic scale conditioning function which will reduce the rate of scale deposition in hard water areas. However, some deposits may still occur in the storage tank; these should be periodically removed.
- 7.2 The amount of usage of the unit will also determine the quantity of scale build up. A regular inspection of the tank every 6 to 12 months will provide longer life of the product and optimum performance (removal of the steam plate assembly will give access to the storage tank) .
- 7.3 The front cover and spout will require a periodic wipe to clean any marks/splashes from use.

## 8.0 FAULT FINDING

Your Elson EBW25 should give trouble free operation, however should a fault occur, the table below should allow most faults to be identified. Fault finding should only be carried out by a competent person.

SYMPTOM	POSSIBLE CAUSE	ACTION
Power light continuous single pulse but unit remains operational	Scale is detected or the unit requires cleaning	Arrange for the unit to be cleaned and de-scaled, continue to use
Power light continuous single pulse and the unit shuts down	More scale detected	The unit requires cleaning and de-scaling
Power light continuous single pulse and the unit shuts down	No water detected	Check water supply to the unit is available and turned on
Power light continuous triple pulse and the unit shuts down	A fault is detected	Call an engineer

SYMPTOM	POSSIBLE CAUSE	ACTION
No indicator lights	<ol style="list-style-type: none"> <li>1. If no water or heat - no power to unit</li> <li>2. If hot water available - no power to indicator diodes</li> </ol>	<ol style="list-style-type: none"> <li>1. Check power supply is correctly connected and switched on and the primary cutout has not operated.</li> <li>2. Check connections to indicators at 4 way plug</li> </ol>
Water flows from vent and primary cutout operates	<ol style="list-style-type: none"> <li>1. Solenoid valve fault</li> <li>2. Level sensor fault</li> <li>3. Electronic control fault</li> <li>4. Low water pressure</li> </ol>	<ol style="list-style-type: none"> <li>1. Check operation of solenoid valve. Replace if necessary</li> <li>2. Check level system</li> <li>3. Check connections to electronic control. Replace if necessary</li> <li>4. Increase inlet pressure</li> </ol>
Steam from vent pipe and primary cutout operates	<ol style="list-style-type: none"> <li>1. Control thermistor fault - open circuit</li> <li>2. Electronic control fault</li> <li>3. Scale build up</li> </ol>	<ol style="list-style-type: none"> <li>1. Check continuity (5Kohms at 100°C)</li> <li>2. Check connections to electronic control. Replace if necessary</li> <li>3. Descale unit</li> </ol>
Drips from outlet	<ol style="list-style-type: none"> <li>1. Incorrect spring tension</li> <li>2. Scale: Debris under tap seal</li> <li>3. Damaged tap seal</li> <li>4 Scale on tap outlet spout</li> </ol>	<ol style="list-style-type: none"> <li>1. Ensure tap headwork nut correctly adjusted</li> <li>2. Remove and clean as necessary</li> <li>3. Replace tap seal</li> <li>4. Clean tap outlet</li> </ol>
Water "runs on" when tap released	<ol style="list-style-type: none"> <li>1. Scale on tap outlet spout</li> <li>2. Scale debris under tap seal</li> <li>3. Damaged tap seal</li> </ol>	<ol style="list-style-type: none"> <li>1. Clean tap outlet</li> <li>2. Replace and clean as necessary</li> <li>3. Replace tap seal</li> </ol>
Stale taste to water	Unit left unused for several days	Empty and allow to refill before use
Tap sticks open	Dirt around handle pivot	Clean with a stiff paint brush

For any faults that cannot be identified using the Fault Finding chart please contact the Elson After Sales Service, telephone (0344) 871 1535.

## 9.0 SPARE PARTS

The following comprehensive list of spare parts is available for your Elson EBW25 water heater. Please refer to the rating label on the right hand side of your heater before ordering to ensure the correct spare parts are obtained.

**Do not replace with parts not recommended by Elson - this will invalidate your warranty and may render the installation dangerous.**

1. Element assembly (incorporating start dry cutout).....	95 607 952
2. Element assembly sealing gasket.....	95 611 816
3. Primary cutout (vent pipe).....	95 612 001
4. Solenoid valve assembly.....	95 605 877
5. Level sensor assembly.....	95 606 971
6. Circuit board .....	95 615 007
7. Outlet tap headwork (inc. handle).....	95 605 071
8. Outlet tap cup seal.....	95 611 731
9. Bezel for tap & cover.....	95 605 072
10. Steam condenser assy 2.5ltr.....	95 607 015
11. Cover assy & screws .....	95 614 309
12. Condenser sealing gasket .....	95 611 817
13. 'O' ring kit.....	95 611 002
14. Manifold assy 2.5ltr.....	95 607 206
15. Outlet spout plastic - tank.....	95 604 668
16. Outlet spout - cover.....	95 604 001
17. Push fit connector 15x15 straight.....	95 607 509
18. Push fit connector 15x15 elbow.....	95 607 510
19. Tank .....	95 608 926
20. Tank drain & seal.....	95 608 929
21. Start dry cutout (element).....	95 612 691
22. Solenoid valve coil.....	95 605 839
23. Fitting kit 2.5ltr Model (not shown).....	95 607 024
24. Wiring harness 4-way (not shown).....	95 612 006
25. Wiring harness complete (not shown).....	95 607 209
26. Thermistor control/steam (not shown).....	95 612 696
27. Steam plate assy 2.5ltr.....	7 030 857

Figure 3: Spares

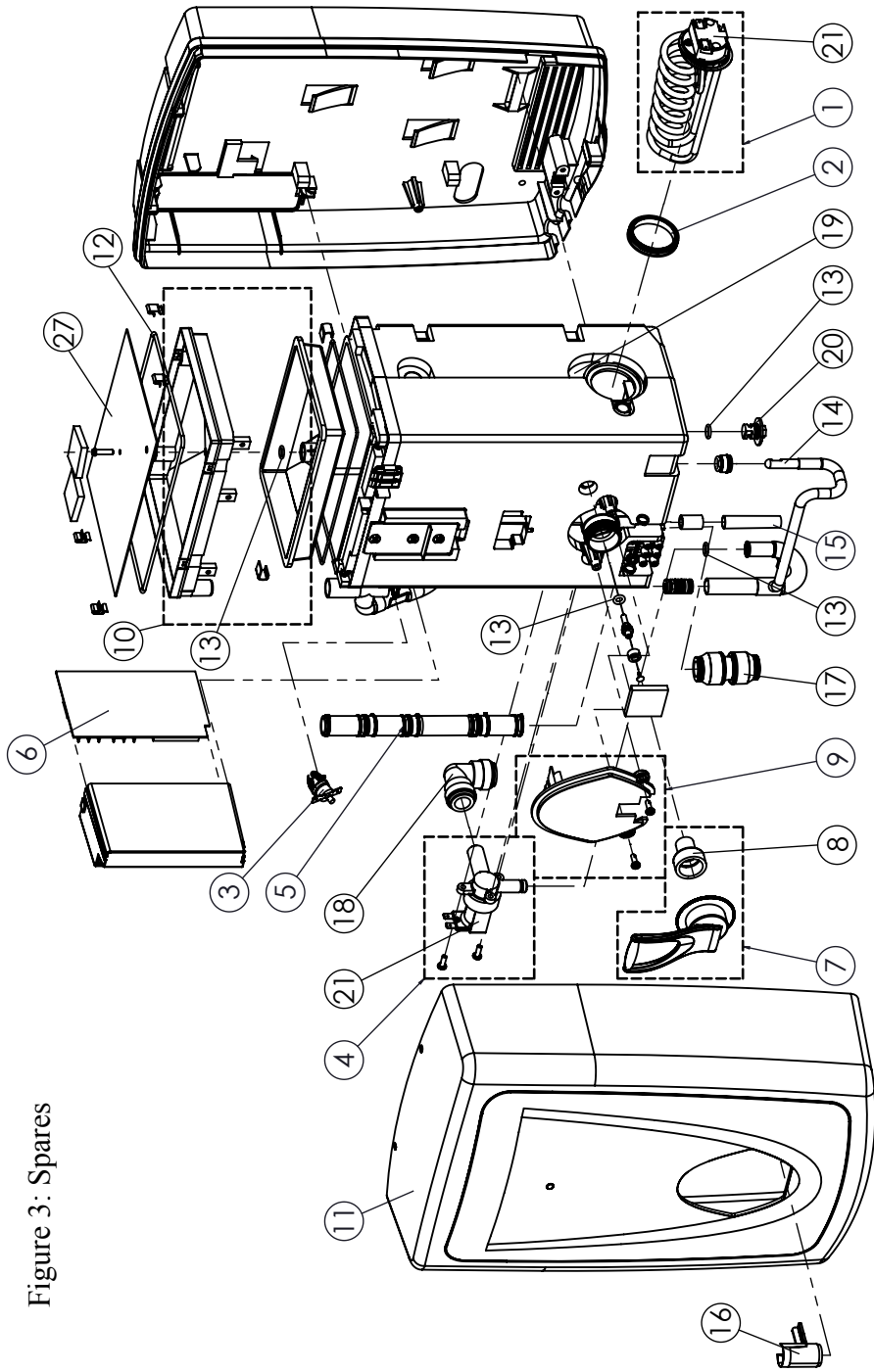

## 10.0 USER INSTRUCTIONS

- 10.1 Once installed the filling and the heating cycles of the Elson EBW25 are completely automatic.
- 10.2 To dispense water, place a suitable container under the outlet spout and pull the tap handle down and towards (or pushed away) the user. The water dispensed will at all times be boiling or close to boiling point so due caution must be taken when using the product.
- 10.3 The tap handle is spring loaded so that when released it will spring back to the "off" position (no flow).
- 10.4 The Elson boiling water dispenser is fitted with two neon indicators. The upper red LED indicates POWER ON. The lower LED indicates TEMPERATURE READY. When the LED is flashing, the unit is commissioning (DO NOT DRAW OFF WATER). When the LED is continuously on, the unit is ready to be used.
- 10.5 If the store of hot water is completely withdrawn, the flow rate from the outlet tap will reduce to the filling rate of the heater (leave for 2 minutes before drawing any more water off). This slow flow rate allows the incoming water to be instantly reheated, it does not indicate a fault with the water heater.
- 10.6 If the unit is not used for a few days the water may become "stale". In these instances it is advisable to draw off the contents and discard the water at least twice to remove the "stale" water. This will ensure that "freshly" boiled water is used to make your drinks etc.
- 10.7 Similarly, if left unused it is possible that some scale residue will collect in the outlet tap. This will cause the outlet water to appear "milky" for a short while. If this condition occurs it is recommended that the first few cups are drawn off and discarded.

## Warranty

This product warranty guards against faulty materials and manufacture for a period of two years from the date of purchase provided that:

- 1 The unit has been installed by a competent person in accordance with the Installation, User Instructions, all relevant Codes of Practice, Regulations in force at the time of installation and that all necessary controls and safety valves have been fitted correctly.
- 2 Any valves and controls are of the Elson recommended type and specification.
- 3 The appliance has not been modified or tampered with in any way, and has been regularly maintained as detailed in the Installation and User Instructions.
- 4 The appliance has been used only for heating potable water.

The appliance warranty does not cover against damage by frost, and the inner container with integral heating element against excessive scale build-up.

This warranty in no way affects the statutory rights of the consumer.

The policy of Elson is one of continuous product development and, as such, we reserve the right to change specifications without notice.

### **Environmental Information**

Elson products are manufactured from many recyclable materials.

At the end of their useful life they should be disposed of at a Local Authority Recycling Centre in order to realise the full environmental benefits.

## Spares Stockists

Electric Water Heating Co.  
2 Horsecroft Place, Pinnacles,  
Harlow, Essex CM19 5BT  
Tel: 0845 0553811  
E-mail: [sales@ewh.co.uk](mailto:sales@ewh.co.uk)

SPD  
Special Product Division, Units 9 & 10  
Hexagon Business Centre,  
Springfield Road,  
Hayes, Middlesex UB4 0TY  
Tel: 020 8606 3567

Parts Center  
Tel: 0845 270 9800  
[www.partscenter.co.uk](http://www.partscenter.co.uk)

Newey & Eyre  
Specialists Products Division  
Please contact your local branch

UK Spares Ltd  
Unit 1155 Aztec West,  
Almondsbury, Bristol BS32 4TF  
Tel: 01454 620500

Advanced Water Company Ltd  
Unit 5D, Enterprise Way, Vale Park,  
Evesham, Worcestershire WR11 1GS  
Tel: 01386 760 066



Fifers Lane,  
Norwich,  
Norfolk, NR6 6XB.  
[www.elsonhotwater.co.uk](http://www.elsonhotwater.co.uk)

After Sales Service  
Tel: (0344) 871 1535  
Service Email: [customer.support@heatraesadia.com](mailto:customer.support@heatraesadia.com)



# **GENERAL SAFETY WARNING**

## **WHERE A PRESSURE REDUCING VALVE IS REQUIRED**

IMPORTANT INSTALLATION NOTE:

WHERE THE INLET SUPPLY TO A PRESSURE REDUCING VALVE (PRV) IS ROUTED THROUGH A HEATED SPACE AND IS FITTED WITH A CHECK VALVE OR OTHER FITTING THAT WOULD PREVENT BACK FLOW, HIGH PRESSURES CAN BE EXPERIENCED IN THE INLET PIPE DUE TO WARMING THAT CAN CAUSE DAMAGE TO THE PRV OR OTHER FITTINGS ON THE INLET SUPPLY.

IN THESE CIRCUMSTANCES, THE INSTALLATION OF A MEANS TO ACCOMODATE EXPANSION AND THUS LIMIT THE PRESSURE RISE IN THE INLET PIPE IS RECOMMENDED.

# WEEE Declaration

Disposal of Waste Equipment by Users in Private Household in the European Union.

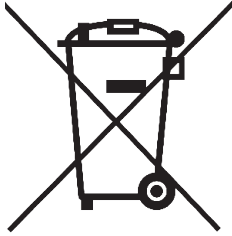

This symbol on the product indicates that this product must not be disposed of with your other household waste. Instead, it is your responsibility to dispose of your waste equipment by handing it over to a designated collection point for the recycling of waste electrical equipment. The separate collection and recycling of your waste equipment at the time of disposal will help to conserve natural resources and ensure that it is recycled in a manner that protects human health and the environment. For more information about where you can drop off your waste equipment for recycling, please contact your local city office, your household waste disposal service or the company where this product was purchased.