

USERS MANUAL

IN-LINE MIXED FLOW



DESTINATION

The in-line mixed flow fans with channels' diameters ranging from 100 to 150 mm are designed for installation in the ventilating systems that require high pressure, powerful air flow.

The pumped air should not contain dust and other solid admixtures, as well as sticky substances and fibrous materials, the temperature of the transferred air must not exceed +45°C. Fans are installed horizontally vertically and can be used both for exhaust and for blowing ventilation. The fans are manufactured as two-speed ones and are designed for long-term operation without switching off mains.

By the type of protection against electrical shock the fans belong to Class II.

The degree of protection against access to the hazardous parts and water intrusions is IPX4.

Design of the fans is being constantly perfected, so some models could differ from other ones ' described in this certificate

THE BASIC TECHNICAL DATA

The fans' designations, their parameters, connective and mounting dimensions are provided in fig 2-3. Fans are intended for connection to 230V AC, 50 Hz. An external 3A fuse is required for each fan unit. It is permitted to use the fan under ambient air temperature from +5°C to +40°C

The scheme of designation of fans.

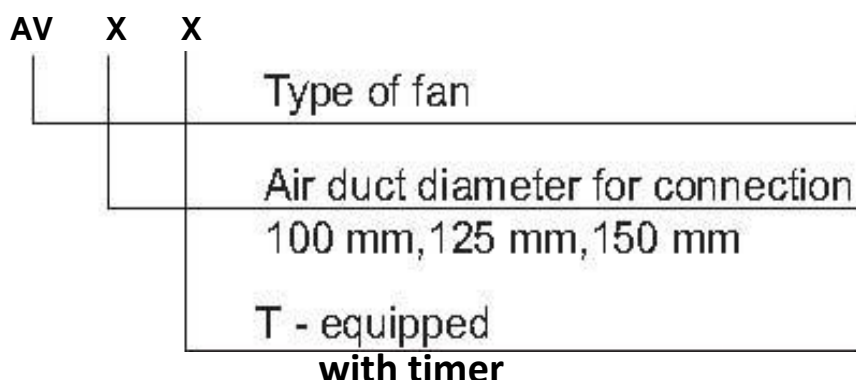

Notes.

The diameter of the air duct should match with the diameter of fan delivery pipe

Type	Air flow, m/h3	R.P.M.	Consumption current, A	Power, W	Launching capacity, mF	Noise level, dBA,3 m	Voltage, V/50Hz	Connection layout
AV 100*	145\187	2180\2385	0,11\0,21	21\33	-	27\36	1-230	Fig.2/3
AV 125*	220\280	1950\2455	0,18\0,27	23\37	-	28\37	1-230	Fig.2/3
AV 150*	405/520	1680\2460	0,17\0,27	30\60	4	33/34	1-230	Fig.2/3

Table 1.

The fans of the AV-series have two working speeds, that is shown in the tab.1 with record through a fraction: in the numerator the minimum velocity, in the denominator the maximal velocity.

*- equipped with timer.

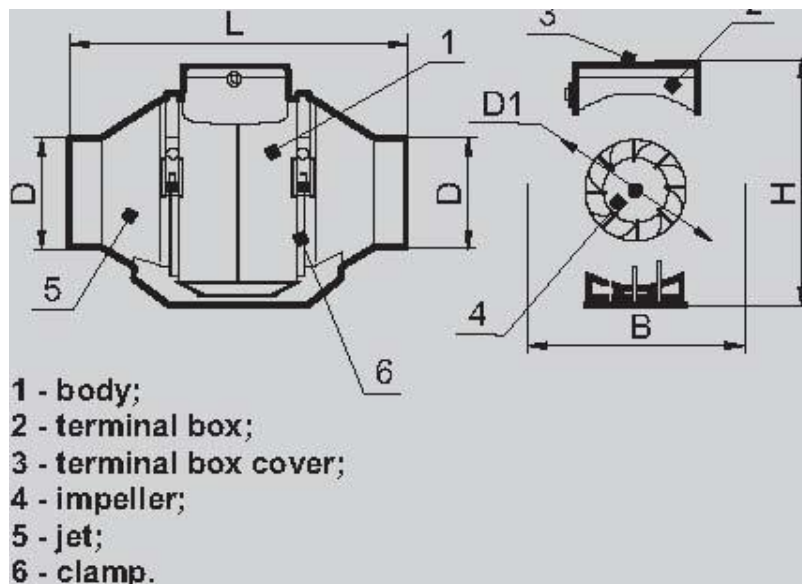

Type	Sizes, mm					Weight, kg
	D	D1	H	B	L	
AV 100	96	126	190	165	246	1,5
AV 125	123	136	190	165	246	1,4
AV 150	148	185	250	220	295	3,3

Table 2



DELIVERY SET

- Fan - 1 piece
- Dowels and screws - 4 pieces
- User's manual
- Packing box

MAINTENANCE

Maintenance of the fan is carried out only after switching it off the mains. Maintenance consists of periodical cleaning of the surfaces from dust and dirt, when the fan is switched off the mains. To remove the dust, use a soft dry brush or compressed air. Blades of the impeller require careful cleaning every 6 months. To do this, dismantle the fan from the channel, take off the clamps 6 and remove the body 1. Using the water solution and detergent, wash the blades of the turbine, avoiding fluid intrusion onto the electric motor.

STORAGE RULES

Store the fan in the manufacturer's packaging in an aerated premise at the temperature from +5°C to + 40°C and relative humidity of the air of not more than 80 % (at T = 25°C).
90411215-Iss 07/10

SAFETY REQUIREMENTS

By the type of protection against electrical shock the fans belong to the Class II. The degree of protection against access to the hazardous parts and water penetration is IPX4. **All actions, related to connection of fans to the mains and adjustment of the timer turn-off delay time are to be carried only if the mains voltage is switched off.**

RECOMMENDATIONS

For horizontal installation of the fan, place an air duct with the length of not less than 1m on the suction side; for vertical installation of the fan, it is necessary to place a valve/ grille at the suction duct end. Connection of the fans is carried out by a specialist electrician who has a special access to the operations performed. Operation of the fans outside the working temperature range is forbidden, as well as exploitation in premises with aggressive impurities in the air. Before connection of the fan to the mains it is necessary to ensure that there are no visible damages of impeller, body, lattice, as well as extraneous objects in the blowing part of the body, which can damage runner vanes. Maintenance and repair of the fan should be carried out only after its switching off the mains.

ATTENTION!

Operation of the fan with extraneous subjects in the blowing part of the body, which can damage or jam the runner vanes, is forbidden. Precautions must be taken to avoid the back-flow of gases into the room from the open flue of gas or other fuel-burnin appliances.



INSTALLATION AND CONNECTION OF THE FAN TO THE MAINS

The fan (fig.1) consists of the body 1 with fixed electric motor and impeller 4. Terminal box cover 3, pipes 5 (pipe diameter corresponds to the diameter of the air duct); quick-detachable clamps 6.

Air moving direction of the air should coincide with the direction of the arrow on the fan body.

For the installation of the fan it is necessary to carry out following operations: **1)** Remove two clamps 6 and to take out the body 1. **2)** Drill holes for dowels, according to the coupling sizes and fix the pipes by means of 4 screws. **3)** Insert the body 1 and fix it with clamps 6. **4)** Connect air ducts of the relevant diameter.

Connection of the fan to the single-phase circuit should be carried out through the switch built-in into the stationary wiring. The gap between contacts of switch at all poles should be not less than 3 mm.

Connection layouts of the fan to the stationary wiring are shown on figs. (2-3). In case of one-speed operation at one speed, it is necessary to connect the wire L of the mains to one of the terminals, corresponding to the selected rotation speed:

L_H maximum speed

L_L minimum speed

Speed of the fan is switched using external switch S1. Fan with timer T (fig 3) ensures automatic turning off the fan after certain time from 2 to 30 minutes, set up by the timer. Turn-off delay time is adjusted, using the handle of potentiometer, rotating it clockwise to increase the delay time and anticlockwise to decrease it.

To connect the fan to the mains, it is necessary to:

- remove the cover from terminal box,
- extend electric wires through the gasket ring, located on the terminal box,
- remove insulation from the ends of wires by 5-6mm, insert them into appropriate terminals until insulation is rested against the metal part of the terminals, and fix them with screws,
- place back the terminal box cover.

ATTENTION!

Launching the fan, equipped with timer, occurs within approximately 5 s after turning on external switch S2.

Fig. 2

Wiring Diagram AV100, AV125 and AV150

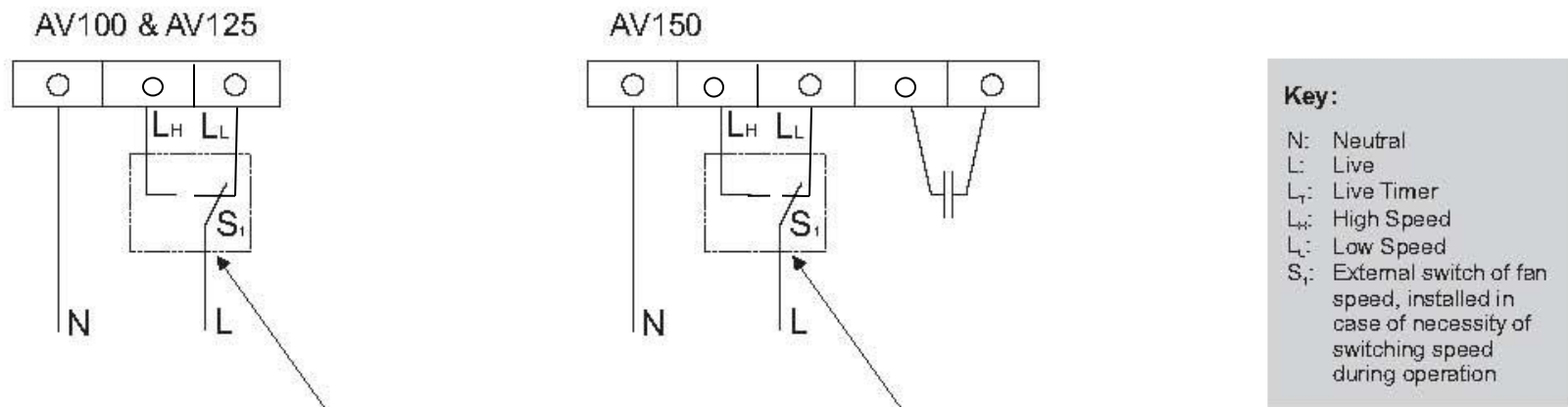

Switch from L to L_L or L_H. This allows for Low or High speed settings from an external switch.

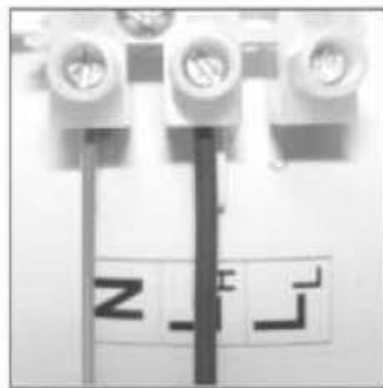

Wiring Photograph: **High** Speed



Wiring Photograph: **Low** Speed

Fig. 3
Wiring Diagram AV100T, AV125T and AV150T

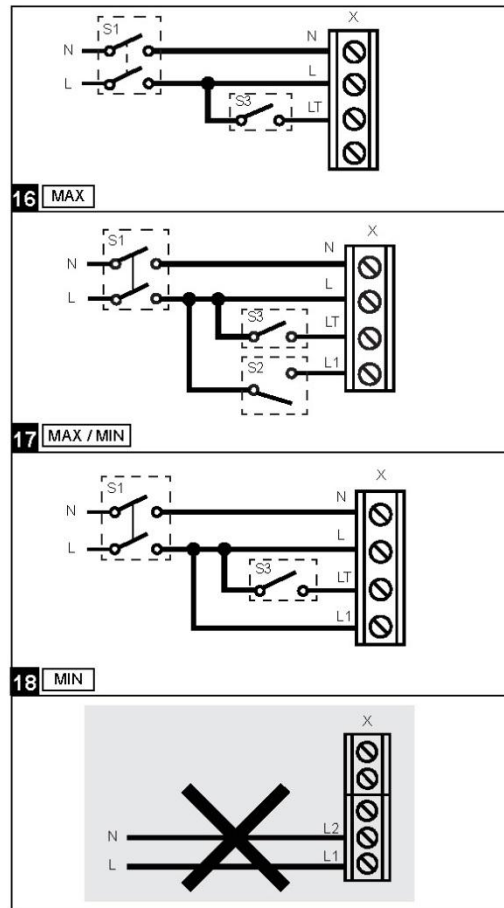



MANUFACTURER'S WARRANTY

The manufacturer guarantees normal operation of the fan during 24 months after the date of its sale through retail network on condition that the rules for its transportation, storage, installation and operation are followed.

In case of absence of the entry specifying the date of sale, the warranty period is calculated from the date of manufacture. In case any fan's malfunction occurs during the warranty period through the fault of manufacturer, the respective customer shall be entitled to replacement of the fan at the manufacturer's location.

Airflow Developments Limited
Aidelle House, Lancaster Road, Cressex Business Park, High Wycombe, Bucks H12 3QP

E-mail: info@airflow.com

Telephone: +44 (0) 1494 525252. Facsimile: +44 (0) 1494 461073

Web: airflow.com

THE ACCEPTANCE CERTIFICATE

The fan complies with the European norms and directives.

Model:

Manufacturing:

Stamp of the inspector

Sold

The name of the trading company, stamp of the shop

Date of sale