

### A: Component Parts

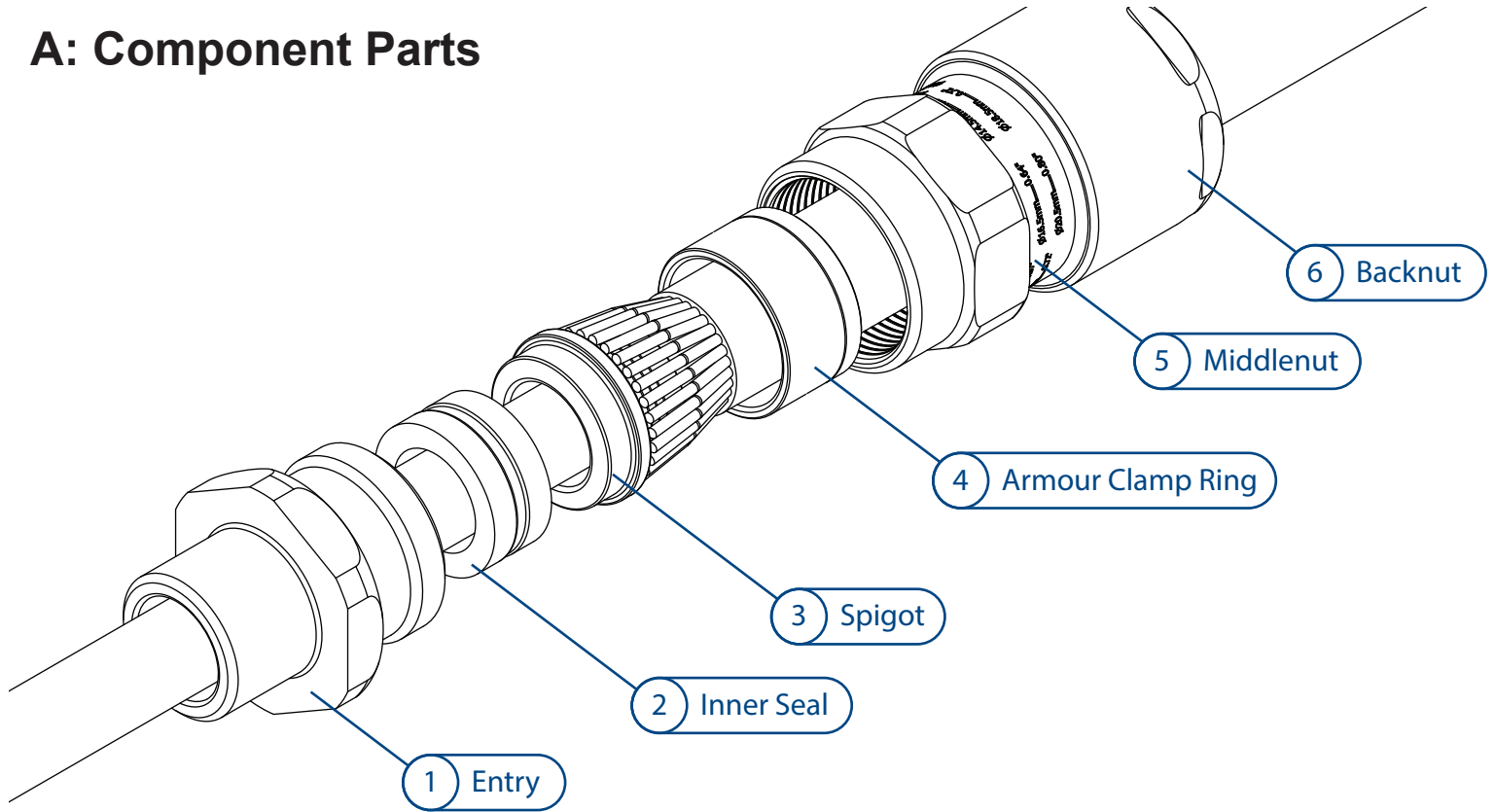

### B: Cable Preparation

Slide shroud (if included), backnut ⑥, middenut ⑤ and armour clamp ring ④ onto cable. Confirm orientation of armour clamp ring is correct (see table below). Cut cable length, strip outer sheath and cut armour to lengths as shown in table below.

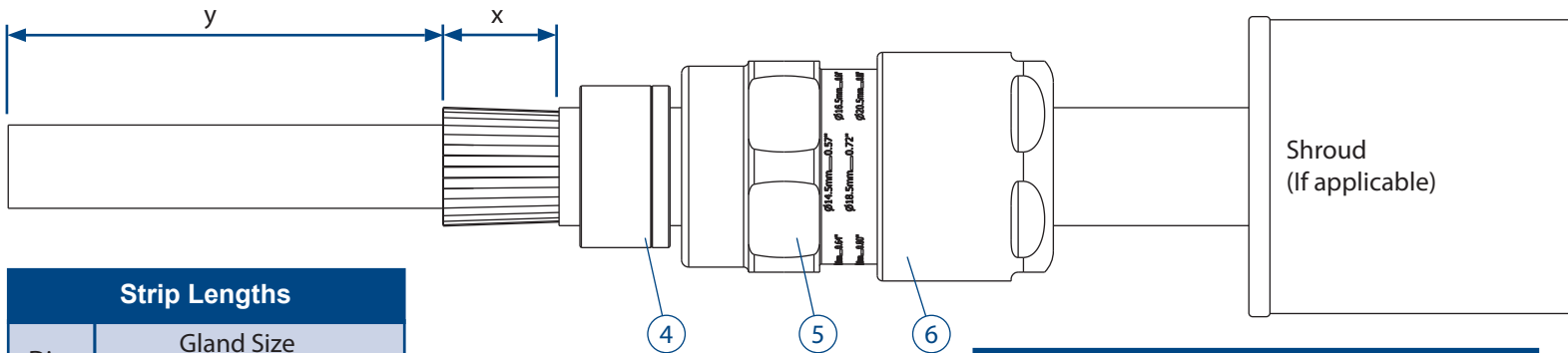

| Strip Lengths |                   |      |      |
|---------------|-------------------|------|------|
| Dim           | Gland Size        |      |      |
|               | Os-C              | C2-F | G-J  |
| x             | 20mm              | 25mm | 32mm |
| y             | To suit equipment |      |      |

| Armour Clamp Ring Orientation |                |                |
|-------------------------------|----------------|----------------|
| Gland Size                    | Orientation    |                |
|                               | Equipment Side | Equipment Side |
| Os-A                          | 0.8 - 1.25mm   | 0 - 0.8mm      |
| B                             | 1.25 - 1.6mm   | 0 - 0.7mm      |
| C-C2                          | 1.6 - 2.0mm    | 0 - 0.7mm      |
| D-F                           | 1.8 - 2.5mm    | 0 - 1.0mm      |
| G-H                           | 2.0 - 3.5mm    | 0 - 1.0mm      |
| J                             | 2.5 - 4.0mm    | 0 - 1.0mm      |

**Tape Armour**  
After tape is spread, ensure ends are trimmed at 90° as shown



# C: Installing Cable Gland

## STEP 1: Fit Armour To Spigot

Slide spigot ③ over cable.

Push armour/braid up to spigot shoulder.

Slide clamping ring ④ up to the armour/braid by hand.

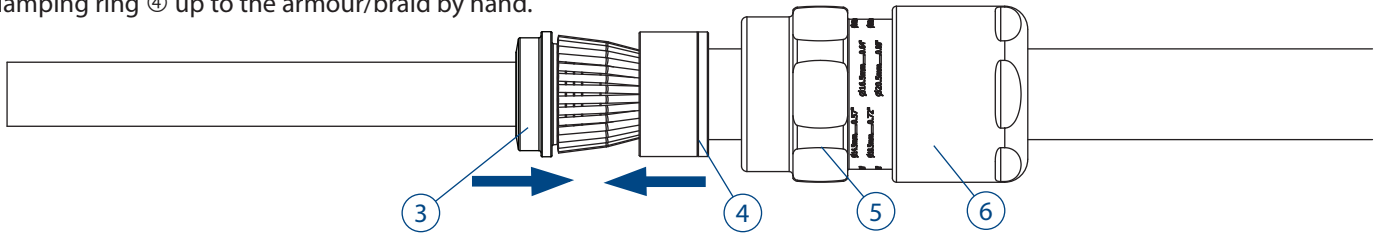

## STEP 2: Prepare to Clamp Armour/Braid

Ensure inner seal ② is removed from assembly.

Slide Entry ① over cable.

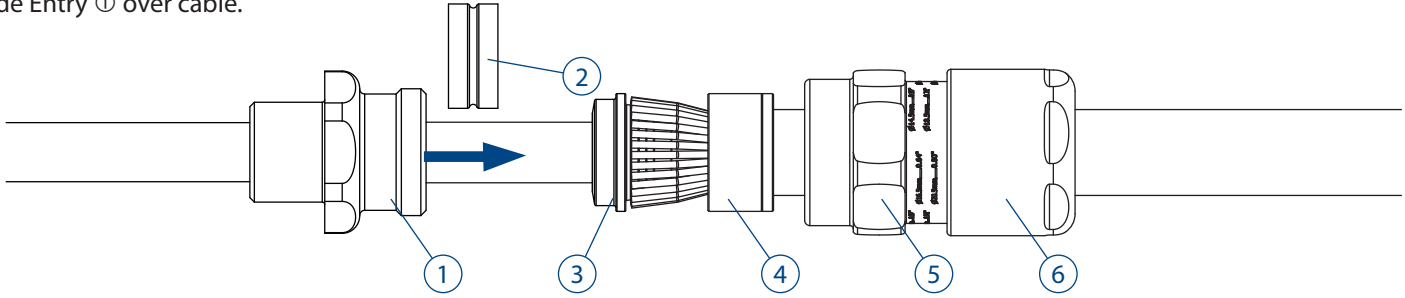

**NOTE:** A spare entry component could be used to clamp the armourings, which removes the need to remove the inner seal of the gland to be assembled.

## STEP 3: Clamp Armour/Braid

Slide middle nut ⑤ up to entry and hand tighten.

If not already screwed into equipment, grip the entry ① with a spanner/wrench.

Use a second spanner/wrench to tighten half to three quarters of a turn.

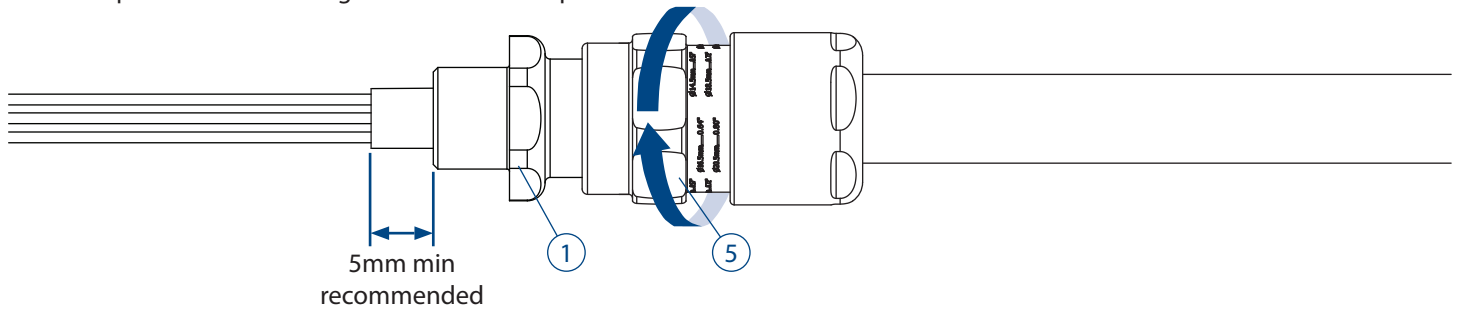

**NOTE:** Support the cable to prevent it twisting. To aid wiring inside the enclosure, it may be beneficial to strip the inner sheath as shown above.

## STEP 4: Inspect Armour/Braid

Unscrew the middle nut ⑤. The armour clamp ring ④ should now be locked in place.

Visually inspect that the armour/braid has been successfully clamped between the spigot ③ and the armour clamp ring ④.

If clamping is not satisfactory, repeat step 3.

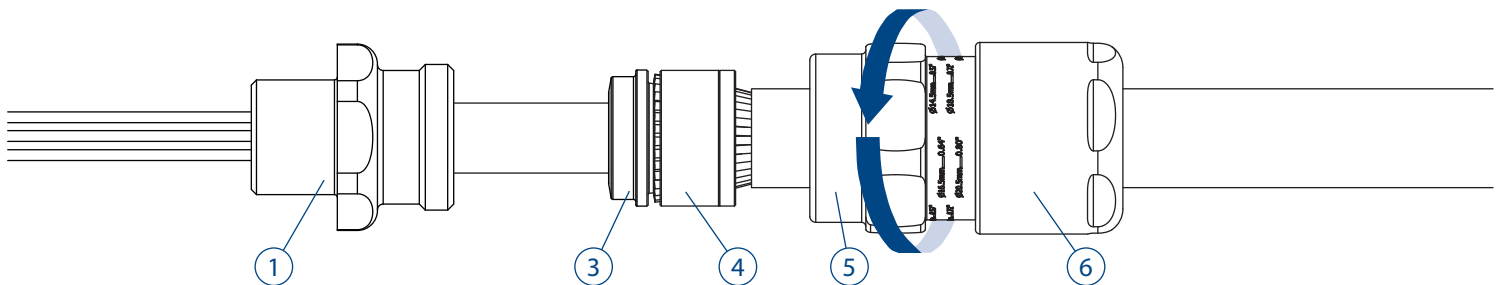

### STEP 5: Install inner seal

Remove entry ① and refit inner seal ②. Replace entry ① to enclosure. If required, use the appropriate IP washer.

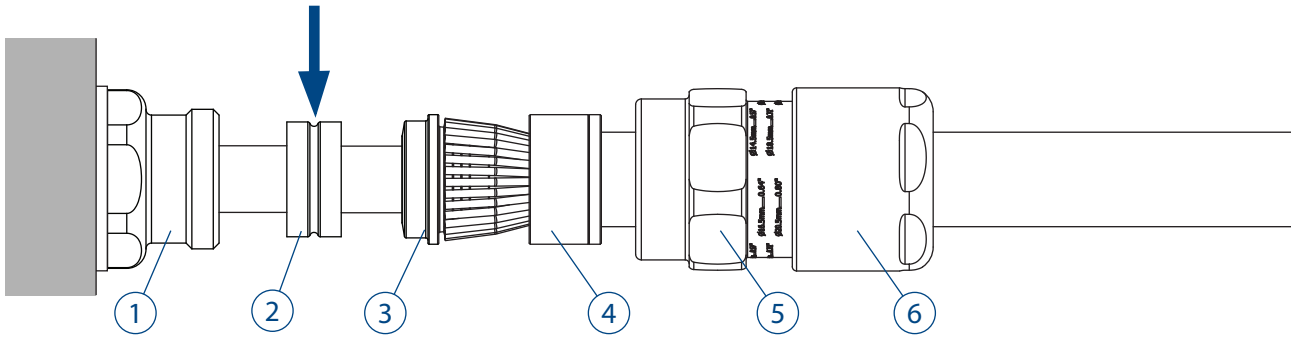

### STEP 6: Compress Inner Seal

With inner seal properly seated into the entry, tighten up the middle nut by hand. Using a wrench/spanner tighten a further 1-2 turns until fully tight.

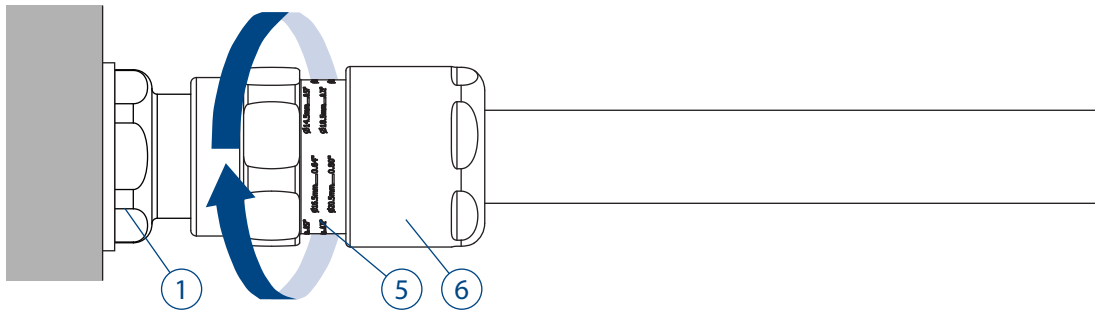

### STEP 7: Install Backnut

Tighten the backnut ⑥ until a seal is formed around the cable.

Use a wrench/spanner to grip the middle nut ⑤.

While preventing the middle nut ⑤ turning, use a second wrench to apply one further full turn to the backnut ⑥.

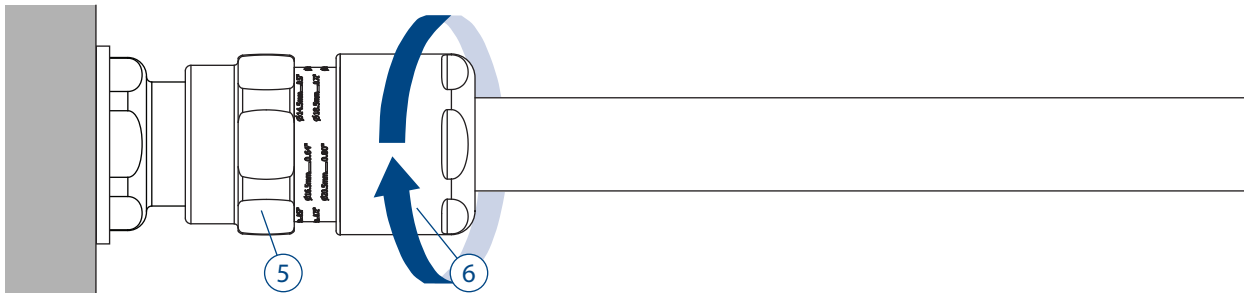

### STEP 8: Inspect Backnut

Use the middle nut ⑤ guide as an indication that the backnut ⑥ is in the correct position to suit cable diameter.

A diameter scale below is provided to assist this process. (Sizes O-F only)

Slide shroud over cable gland if applicable.

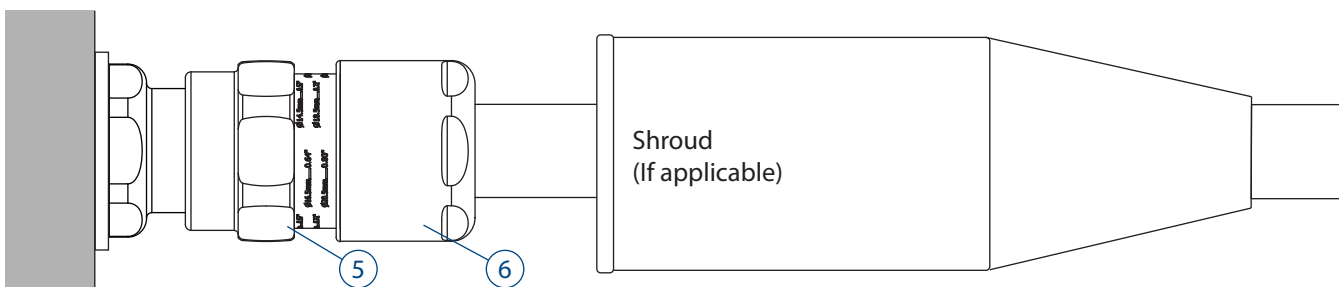

# Technical Information

# 501 453 RAC



## TECHNICAL DATA

**Cable Gland Type:** 501/453/RAC  
**Equipment Type:** Group II Compression Cable Glands  
**Ingress Protection:** IP66, IP67, IP68\*  
 \*30m for 7 days with thread sealant to EN60529  
**Operating Temp:** -60°C to +100°C

## CERTIFICATION DETAILS

Ex db IIC Gb / Ex eb IIC Gb / Ex nR IIC Gc / Ex tb IIIC Db  
**ATEX:** CML19ATEX1167X UKEX: CML 21UKEX1161X  
**IECEX:** CML19.0045X  
**IEEx:** 14.0272X  
**EAC:** No EA3C RU C-GB.HA91.B.00264/21  
**CSA:** No1015065  
 Ex db Ex eb IIC Gb  
 Class I Div 2 ABCD, Class II Div 2 EFG, Class III  
 c CSA us: AEx eb IIC Gb, AEx tb IIIC Db  
 Class I Zone 1, Zone 21

## INSTALLATION NOTES

1. All cable glands must be installed by a suitably trained and competent individual.
2. Entry threads are in accordance with Metric BS3643 or NPT B1.20.1
3. Installer must check material compatibility with enclosure and environment.
4. To maintain IP66, 67 & 68, Hawke certified sealing washer or other approved sealing method must be used.
5. Sealing face surface must be smooth and free from damage
6. Wall thicknesses depended on thread length or retention type (locknut etc). Exd must maintain the requirements of IEC/EN 60079-1
7. All entries must be installed perpendicular to the mounting surface.

## ACCESSORIES

Hawke offer the following accessories to enable correct sealing and ground of cable gland.

**Shroud:** For additional corrosion protection  
**Locknut:** To secure gland into position  
**Sealing Washer:** For additional ingress protection  
**Earth Tag:** For external bonding point  
**Serrated Washer:** To prevent vibration loosening locknuts

## SCHEDULE OF LIMITATIONS:

1. These cable glands are designed for use with unarmoured or appropriate Steel Tape Armour (STA), Steel Wire Armour (SWA), and appropriate braided cable. These cables must be with extruded sealing (solid polymeric) completely surrounding the 'core' (insulation and conductor), allowing for no holes or ventilation through the inner jacket or along the cores.
2. The Hawke 501/4 series cable gland connectors, when used in Class 1 Division 2 Classified areas, are not suitable to be interfaced with an explosion proof enclosure containing arcing and sparking devices, unless installed in conjunction with an approved explosion proof sealing fitting.
3. These gland are suitable for use with Certified Marine Shipboard armored/ unarmored cables constructed to CSA Std 245 and IEEE45/IEC600092-353 Standards, or certified equivalent, for use on Shipboards and Offshore.
4. Must comply with Canadian Electrical Code and National Electric Code requirements for threaded entries.(CSA Only)
5. For Ex e applications, a sealing washer or thread sealant may be required between the enclosure and the gland to maintain the IP rating of the enclosure.
6. When used with unarmored or braided cables are only suitable for use with fixed apparatus.

## TORQUE VALUES

All torque values below were generated on metallic mandrels. For cable, it is recommended that the assembly instructions are followed.

| Torque Figures N/m |    |    |    |    |    |    |    |    |    |  |
|--------------------|----|----|----|----|----|----|----|----|----|--|
| Gland Size         | Os | O  | A  | B  | C  | C2 | D  | E  | F  |  |
| Middlenut Torque   | 6  | 6  | 8  | 8  | 10 | 15 | 15 | 28 | 35 |  |
| Backnut Torque     | 12 | 12 | 20 | 30 | 35 | 45 | 56 | 60 | 75 |  |

| CABLE GLAND SELECTION TABLE |                   |           |                          |           |               |               |              |       |                               |       |                   |                |                    |                |
|-----------------------------|-------------------|-----------|--------------------------|-----------|---------------|---------------|--------------|-------|-------------------------------|-------|-------------------|----------------|--------------------|----------------|
| Size Ref.                   | Entry Thread Size |           | Cable Acceptance Details |           |               |               |              |       |                               |       | Compressed Length | Maximum Length | Hexagon Dimensions |                |
|                             |                   |           | Inner Sheath             |           |               |               | Outer Sheath |       | Steel Wire Armour/ Tape/Braid |       |                   |                |                    |                |
|                             | Standard Seal     |           | Alternative Seal (S)     |           | Orientation 1 | Orientation 2 |              |       |                               |       |                   |                | Across Flats       | Across Corners |
|                             | Metric            | NPT       | Min.                     | Max.      |               |               | Min.         | Max.  | Min.                          | Max.  |                   |                |                    |                |
| Os                          | M20*              | ½"        | 3.2                      | 8.0       | ---           | ---           | 5.5          | 12.0  | 0.8/1.25                      | 0/0.8 | 52.0              | 81.0           | 24.0               | 26.5           |
| O                           | M20*              | ½"        | 6.5                      | 11.9      | ---           | ---           | 9.5          | 16.0  | 0.8/1.25                      | 0/0.8 | 52.0              | 81.0           | 24.0               | 26.5           |
| A                           | M20               | ½" - ¾"   | 10.0                     | 14.3      | 9.0           | 13.4          | 12.5         | 20.5  | 0.8/1.25                      | 0/0.8 | 53.0              | 83.0           | 30.0               | 32.5           |
| B                           | M25               | ¾" - 1"   | 13.0                     | 20.2      | 9.5           | 15.4          | 16.9         | 26.0  | 1.25/1.6                      | 0/0.7 | 59.5              | 95.0           | 36.0               | 39.5           |
| C                           | M32               | 1" - 1¼"  | 19.5                     | 26.5      | 15.5          | 21.2          | 22.0         | 33.0  | 1.6/2.0                       | 0/0.7 | 64.0              | 98.0           | 46.0               | 50.5           |
| C2                          | M40               | 1¼" - 1½" | 25.0                     | 32.5      | 22.0          | 28.0          | 28.0         | 41.0  | 1.6/2.0                       | 0/0.7 | 68.3              | 105.0          | 55.0               | 60.6           |
| D                           | M50               | 1½" - 2"  | 31.5                     | 42.3/44.4 | 27.5          | 34.8          | 36.0         | 52.6  | 1.8/2.5                       | 0/1.0 | 79.0              | 133.0          | 65.0               | 70.8           |
| E                           | M63               | 2" - 2½"  | 42.5                     | 54.3/56.3 | 39.0          | 46.5          | 46.0         | 65.3  | 1.8/2.5                       | 0/1.0 | 78.4              | 126.0          | 80.0               | 88.0           |
| F                           | M75               | 2½" - 3"  | 54.5                     | 65.3/68.2 | 49.5          | 58.3          | 57.0         | 78.0  | 1.8/2.5                       | 0/1.0 | 83.7              | 134.0          | 95.0               | 104.0          |
| G**                         | M80               | 3½"       | 67.0                     | 73.0      | ---           | ---           | 75.0         | 89.5  | 2.0/3.5                       | 0/1.0 | 95.6              | 121.0          | 106.4              | 115.0          |
| H**                         | M90               | 3½"       | 67.0                     | 77.6      | ---           | ---           | 75.0         | 89.5  | 2.0/3.5                       | 0/1.0 | 95.6              | 121.0          | 115.0              | 130.0          |
| J**                         | M100              | 4"        | 75.0                     | 91.6      | ---           | ---           | 88.0         | 104.5 | 2.5/4.0                       | 0/1.0 | 95.6              | 121.0          | 127.0              | 142.0          |

\*Sizes Os and O are available with an M16 thread size. If M16 entry is used on O size cable glands the maximum cable inner sheath diameter is limited to 10.9mm.  
 \*\*Sizes G-J not CSA approved

### EU Declaration of Conformity in accordance with European Directive 2014/34/EU and UK Statutory Instrument 2016/1107

**Manufacturer:** Hawke International, Oxford Street West, Ashton-under-Lyne, OL7 0NA, United Kingdom  
**Equipment:** 501/453/RAC  
**Provisions of the Directive fulfilled by the Equipment:** Group II Category 2GD Ex db eb IIC Gb, Ex nR IIC Gc, Ex tb IIIC Db - IP66 67  
**Harmonized Standards used:** EN 60079-0:2018, EN60079-1:2014, EN60079-7:2015+A1:2018, EN60079-15:2019, EN60079-31:2014  
**Notified Body for EU-Type Examination:** CML B.V. 2776 Amsterdam, NLD  
**EU-type Examination Certificate:** CML19ATEX1167X, CML19ATEX4507X (Ex nR)  
**Notified Body for production:** 0598  
**Approved Body for UK-Type Examination:** CML B.V. 2503 Chester, UK  
**UK-type Examination Certificate:** CML 21UKEX1161X, CML21UKEX4133X (Ex nR)  
**Approved Body for production:** 1180

On behalf of the above named company, I declare that on the date the equipment, accompanied by this declaration, is placed on the market the equipment conforms with all technical and regulatory requirements of the above listed directives.

Andrew Reid  
 Technical Manager

[www.ehawke.com](http://www.ehawke.com)

UK Office Sales: +44 (0) 161 830 6698  
 Oxford Street West, Technical: +44 (0) 161 830 6697  
 Ashton-Under-Lyne, Fax: +44 (0) 161 830 6648  
 Lancashire. OL7 0NA. UK E-mail: sales@ehawke.com

Hawke International is a division of Hubbell Ltd.  
 Registered No. 669157 in England. Registered Office:  
 Cannon Place, 78 Cannon Street, London EC4N 6AF.  
 A member of the Hubbell Group of Companies